

TEXTRON Fastening Systems

THREADED
FASTENERS FOR
PLASTICS

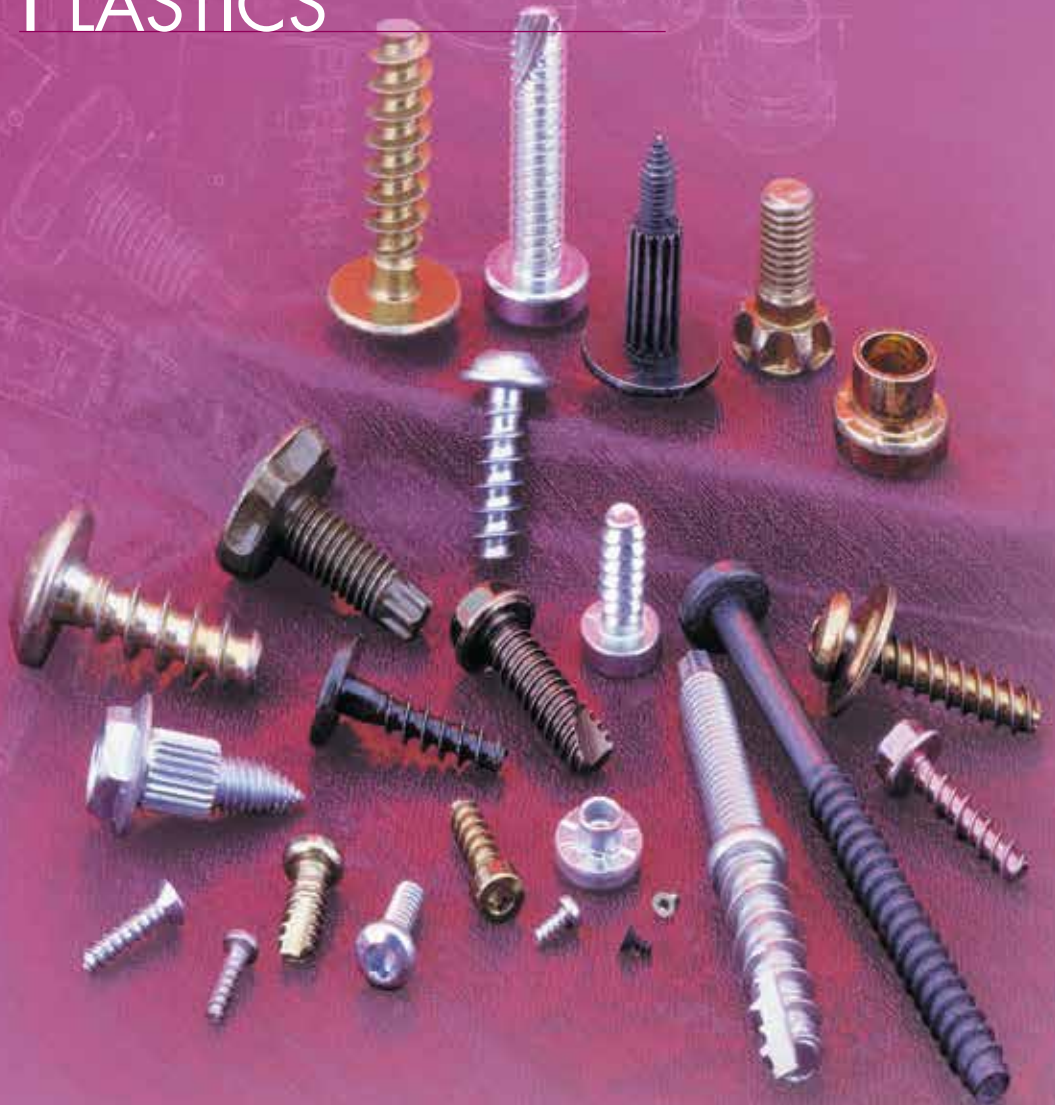



THREADED FASTENERS FOR PLASTICS

Threaded Fasteners for Plastics vs. Standard Screws 4

JOINTS IN PLASTIC

Properties of Plastics. 6
 Installing a Threaded Fastener in Plastics 7
 Design Issues and Fastener Selection 8
 Fastener Selection Chart 10

THREADED FASTENERS FOR THERMOPLASTICS

Delta PT® Fasteners 11
 PT® Fasteners. 13
 DST Fasteners 16
 Plastite® 48 Fasteners 18
 Plastite® 45 Fasteners 21

THREADED FASTENERS FOR THERMOSET PLASTICS

Duro-PT® Fasteners 24

OTHER THREADED FASTENING SOLUTIONS

Powergrip® Fasteners for Layered Assemblies 27
 PlasTORX® Fasteners for Molded Assemblies. 28
 Perma-Nut® Threaded Inserts 30
 Rivscrew® Threaded Rivets 32
 Other Threaded Fasteners for Plastics. 34
 TORX PLUS® Drive System. 35

DEFINITIONS

Glossary 36

FASTENERS FOR PLASTICS IMPROVE ASSEMBLY & PERFORMANCE

Case Histories 37

TFS: THE GLOBAL LEADER IN FASTENING & ASSEMBLY SOLUTIONS

Non-Threaded TFS Products for Plastic Applications 40
 Other TFS Products and Services 41

Plastics continue to open up a world of design opportunities, yet present some unique fastening problems. Whether you're fastening plastic to plastic or plastic to another material, Textron Fastening Systems (TFS) offers a wide selection of high-performance fasteners engineered to meet the requirements of your application.



SELECTING THE RIGHT FASTENER

With thousands of different polymers available today, there can be no absolute guidelines to follow when fastening these materials. Laboratory testing of fasteners in the subject material is the only way to determine if acceptable performance levels can be achieved.

For maximum performance, a fastener should be selected early in the design process. Textron Fastening Systems applications engineers are available to help you every step of the way, from selection and testing to boss design.

WHY USE SPECIAL FASTENERS FOR PLASTICS?

Each type of plastic has its own set of performance issues, such as ductility, thermal expansion and clamp retention. Selecting a fastener that can best match these requirements is critical to the overall performance of an application.

Type B, type AB and other standard fasteners, with wide flank angles and shallow threads, were designed for use in sheet metal and can not meet the dynamic requirements of plastics.



OPTIMAL PERFORMANCE

Fasteners specially designed for plastics can optimize performance in specific types of materials. By selecting the proper fastener, you may obtain:

- Higher strip-out torque values
- Increased resistance to loosening
- Higher pull-out values

REDUCED IN-PLACE COSTS

Proper fastener selection may allow the use of thinner bosses and eliminate the need for supplementary locking devices. This can reduce in-place costs through:

- Reduced material usage
- Reduced cycling times
- Elimination of inserts and adhesives
- Streamlined assembly

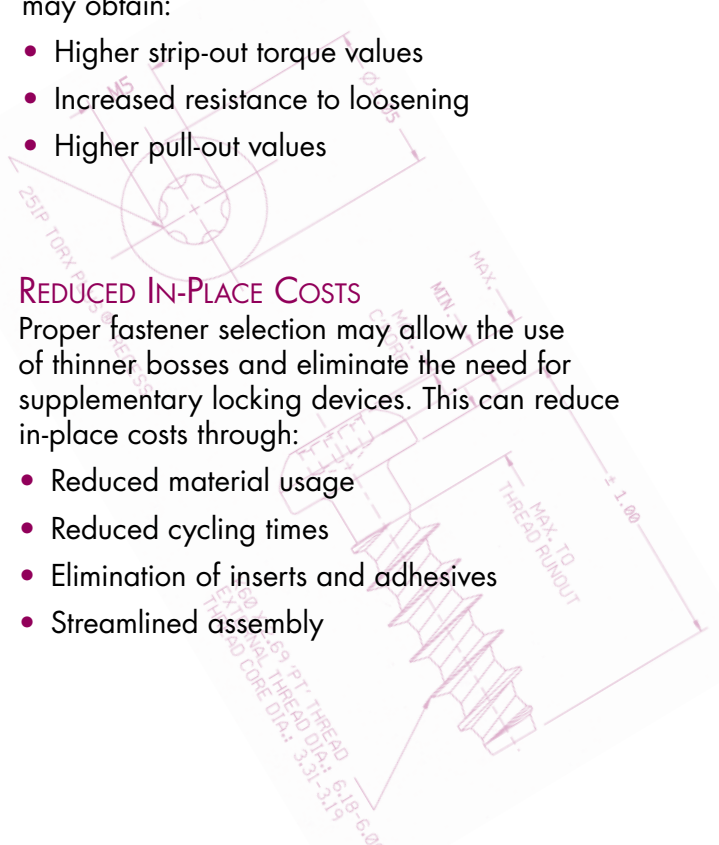

FASTENERS FOR PLASTIC VS. STANDARD SCREWS

Standard Fastener

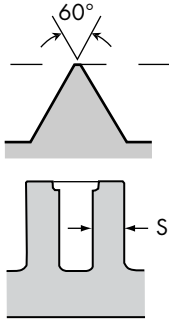

Typical Boss Design for Standard Screw

Special Fastener for Plastics

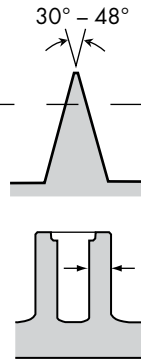

Typical Boss Design for Fastener for Plastics

NARROW THREAD PROFILES MAXIMIZE PERFORMANCE

Type B, type AB and other standard fasteners have a wide thread profile (also called flank angle) of 60°.

Special fasteners for plastics have special thread profiles to meet the needs of these unique materials. These narrower thread profiles, ranging from 30° to 48°, reduce radial stress and expansion. This in turn maximizes fastener performance.

Because radial stress is reduced, special fasteners for plastics allow the use of smaller bosses than standard screws, as shown at left. Using smaller bosses can reduce your overall costs through decreased material usage and molding cycle times.

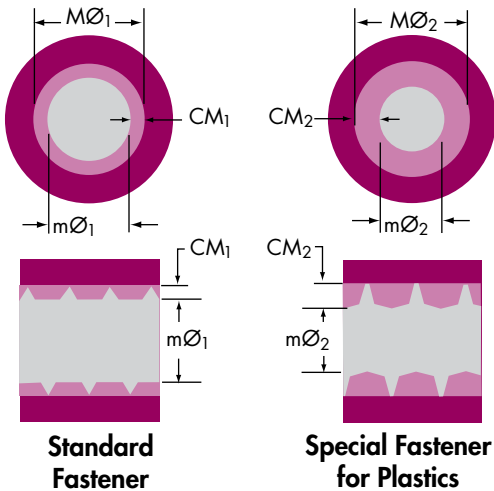

INCREASED RESISTANCE TO PULL-OUT

In the illustrations at left, CM represents the area subjected to shear when an axial load is applied.

Because the special fastener for plastics has a smaller minor diameter ($m\phi$) and a higher thread profile, it contains a larger volume of material (CM) and has a larger axial shear area.

This greater area of thread engagement means the special fastener for plastics is more resistant to pull-out.

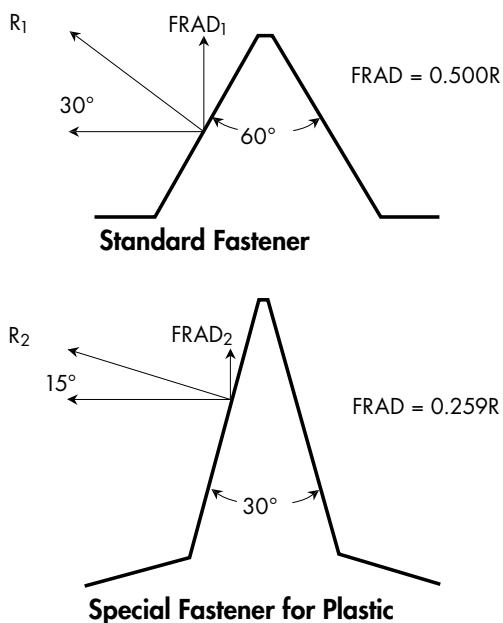

LOWERED RADIAL STRESS PREVENTS BOSS DAMAGE

Radial force (FRAD) is an undesirable force since it creates outward stress and can damage the boss.

Although the same volume of material is displaced between the 60° thread and the 30° thread, **the radial force generated by the 30° thread is approximately one-half that of the 60° thread.**

In the photo at right, the plastic boss with a 60° thread fastener shows radial stress and subsequent damage. The plastic boss with a special fastener for plastics shows **reduced radial stress.**



Standard Fastener **Special Fastener for Plastics**

THE PROPERTIES OF PLASTICS

The fastening performance of plastics is affected by several factors:

- Flexural modulus (stiffness of material)
- Filler and/or reinforcement content (amount of glass, etc. added to material)
- Thermal expansion rate
- Creep rate



FLEXURAL MODULUS

Flexural modulus is the best indicator of how a plastic will respond to fasteners. Generally, the lower the flexural modulus, the more the material will flow and allow the formation of threads.

Thermoplastics with a higher flexural modulus also allow the formation of threads, but usually require a fastener with a low helix angle to avoid excessive drive torque.

Plastics with a high flexural modulus, including thermosets, are too stiff for thread forming and will require thread-cutting fasteners.

There are definite exceptions to these guidelines which can adversely affect fastening performance. Involve our application specialists early in the design process to maximize joint reliability.

THE EFFECTS OF FILLERS ON FASTENING

Fillers and reinforcements change one or more properties of the thermoplastic. They can also affect fastening performance. For example, impact-resistant resins tend to act more ductile than their flexural modulus would indicate. Lubricants added for molding, such as silicone, tend to reduce drive torque but can negatively affect clamp load.

Again, it is important to test your application early in the design process to ensure optimal performance.

THERMAL EXPANSION RATE

The stress/strain curve for thermoplastics is very temperature dependent. Plastics expand much faster than metals do when subjected to the same thermal loading.

Since very few joints operate at constant temperatures, thermal expansion or contraction is virtually universal. This will affect clamp load. However, this is only a problem if the application uses materials with dissimilar expansion rates and the temperature change is significant.

CREEP RATE

Under load or heat all plastics will creep, or permanently deform. Creep will, in turn, cause a loss in clamp load. The chart at left demonstrates the loss of clamp load, at a stable temperature, over 64 hours for a #8 Plastite® fastener driven into acetal resin.

However, creep can be compensated for in joint design through a variety of methods. See page 9 for more details.

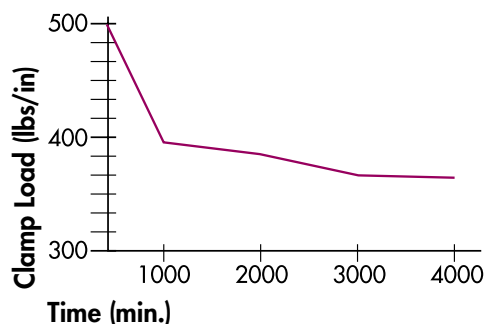
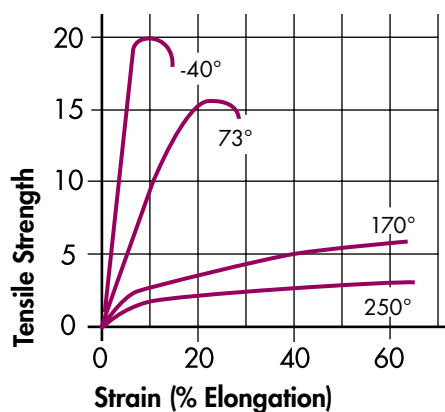

INSTALLING A FASTENER IN PLASTIC

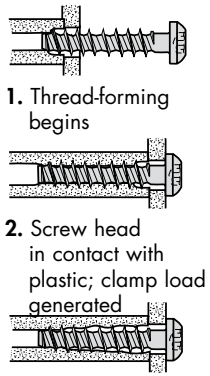

1. Thread-forming begins
2. Screw head in contact with plastic; clamp load generated
3. Strip-out torque level met or exceeded; boss damage occurs

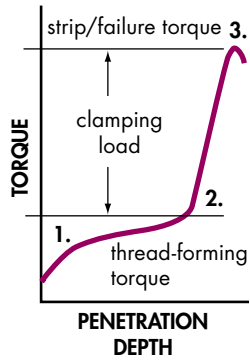

THREAD-FORMING AND STRIPPING TORQUE

Because friction increases as penetration increases, the differential between the thread-forming torque and the strip (failure) torque must be maximized.

Proper seating torque varies from application to application, so contact a Textron Fastening Systems applications engineer for assistance.

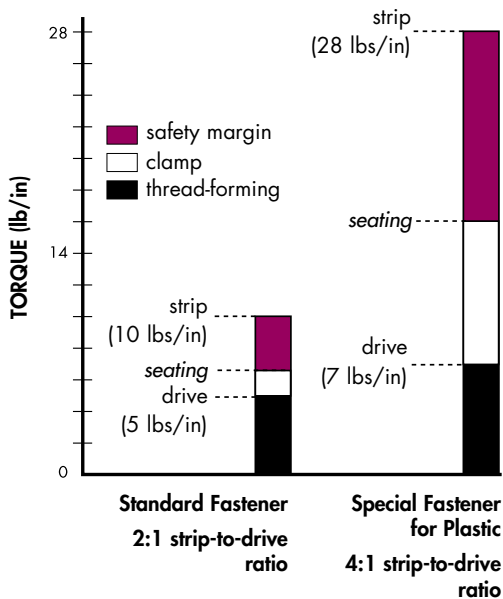

DRIVE-TO-STRIP RATIO

As demonstrated in the chart to the left – based on testing – the fastener for plastic has a much higher drive-to-strip ratio, so the joint is less likely to be damaged during installation.

The standard screw has a safety margin of only 3.5 lbs/in. The special fastener for plastic has a safety margin of 12 lbs/in.

Note: The chosen seating torque was 65% of the failure torque, based on testing.

INFLUENCE OF DRIVER SPEED

Increased drive gun speed can negatively affect the quality of the joint.

During installation, as the RPMs increase, so does the amount of heat that is generated. Too much heat can break down the plastic and lower the failure torque level.



DETERMINING PROPER SEATING TORQUE

Textron Fastening Systems can run complete tests on your application to determine your optimal fastening solution, including fastener selection, joint design and seating torque.

For a recommendation on how to run your own tests to determine proper seating torque, please see page 9.

DESIGN ISSUES AND FASTENER SELECTION

There are several factors which can affect a fastener's ability to achieve satisfactory performance, including:

- Pilot hole diameter
- Length of engagement
- Boss design

Though product design may dictate certain restrictions, laboratory testing will determine the proper combination of these factors for your application.

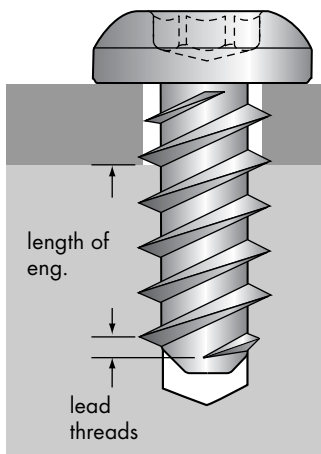

THREAD ENGAGEMENT & PILOT HOLE DIAMETER

Thread engagement is the amount of thread flank depth that is filled by the application material. It is often expressed as a percentage. A hole diameter equal to the major diameter of the threads would have a thread engagement of 0%. In moderately stiff materials, you should start with a hole size that provides 75% to 80% thread engagement.

A hole that creates a thread engagement of over 100% does not improve performance. It will, however, increase required drive torque, because the walls of the hole must expand to make room for the screw.

If the hole size is fixed, you will need to adjust the thread style or length of engagement to reach the appropriate performance requirements.

Each fastener for plastics has its own parameters. For optimal performance, contact a Textron Fastening Systems applications engineer for assistance.

LENGTH OF ENGAGEMENT

Length of engagement is the measurement of full-sized fastener threads engaged in the nut material. The length of the lead thread (usually about one-half the fastener diameter) is not counted in the length of engagement, since its reduced size minimizes any performance benefits.

Length of engagement is often expressed in relationship to the nominal diameter of the screw; e.g. 2 to 2-1/2 diameters of engagement.

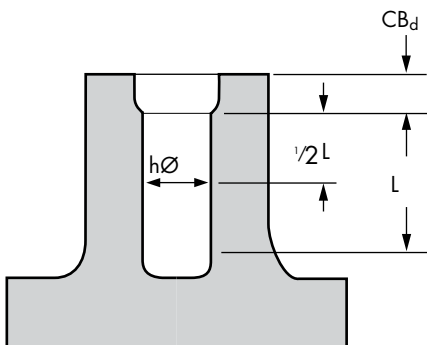

BOSS DESIGN

Drafted holes ease molding in thermoplastics, but can affect thread engagement. Always utilize the minimum amount of draft possible to retain good mold function.

Generally, the nominal hole size ($h\varnothing$) is calculated at a depth equal to half of the fastener's total length of engagement (L), not including the counterbore.

Follow the specific boss design recommendations listed for each threaded fastener.

DESIGN ISSUES AND FASTENER SELECTION



COMPENSATING FOR THE EFFECTS OF CREEP IN A JOINT
As stated previously, under load or heat, all plastics will creep. There are several methods to compensate for, or reduce, the effects of creep in a joint.

- Reduce the stress at the bearing surface by one or more of the following:
 - increase the fastener head diameter
 - add a flat washer
 - reduce the clearance hole diameter
 - reduce initial clamp load at assembly
- Add a spring element to the joint such as a helical and flat washer combination
- Add a metal sleeve in the clamped component to carry some of the clamp load
- Use a shoulder bolt to transfer the load to the nut member
- Increase stiffness of plastic by adding a filler or changing the base resin

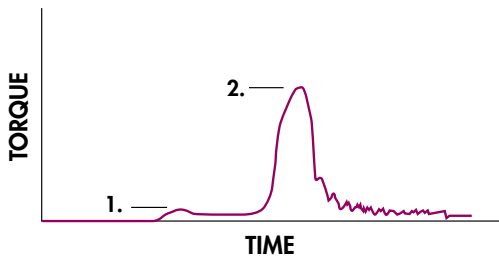

Through Hole Signature Curve

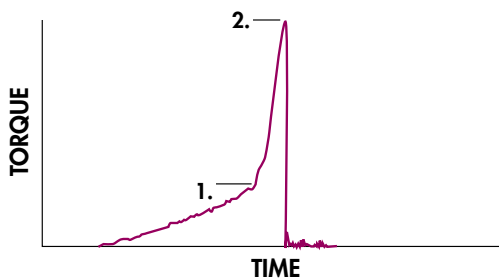

Blind Hole Signature Curve

- 1 – Peak Drive Torque: level at which the materials are drawn together and the fastener seats
- 2 – Ultimate Torque: level at which the joint fails; usually from strip-out

TESTING TO DETERMINE PROPER SEATING TORQUE

The following are general recommendations only.

1. Gather enough sample applications to generate a statistically significant sampling – a minimum of 30 per specific joint condition. These samples must include all components in the joint stack-up such as clamping components, nut members and fasteners.
2. Use a drive gun that can torque the fasteners to failure and has the same RPM as the drive gun that will be used in production.
3. Use a torque measuring device and a strip chart or graph and capture the peak drive torque and ultimate torque values. Drive the fasteners to failure. Calculate the average of the peak drive values and of the ultimate torque values.
4. Next calculate the average of these two resulting values. This is the target seating torque. Factor a value of $\pm 10\%$ for gun accuracy. Compare this torque window to $+3SD$ (standard deviation) of the average drive torque value and $-3SD$ of the average ultimate torque value. If there is no overlap of the two regions, the torque window will allow the fasteners to be seated without failure at assembly. If there is overlap in either of the two regions, a redesign of the joint is warranted.

For assistance, please contact a Textron Fastening Systems applications engineer.

SELECTING THE RIGHT THREADED FASTENER

The following chart is intended only as a starting point in the selection of fasteners. The fastener must be matched to the properties of the material. Drive to strip ratios, clamp retention, and other performance issues are directly affected by the fastener you choose. Please contact a Textron Fastening Systems applications engineer for assistance in selecting the optimum fastener for your design.

INCLUDED MATERIALS		FLEXURAL MODULUS (PSI)	FASTENING SOLUTION	
THERMOPLASTICS	ductile	Polyethylene (PE)	Delta PT® fastener, PT® fastener, or DST fastener	
		Polypropylene (PP)		
	ductile	Polycarbonate (PC)	340,000	Delta PT fastener, PT fastener, twin helix Plastite® fastener, or DST fastener
		ABS, 0-20% glass fill	350,000	
		Polyamide 66 (PA)	350,000	
		Acetal (AC)	400,000	
		Polystyrene (PS)	430,000	
		Polypropylene, 40% talc fill (PP40)	500,000	
	Polyphethylene Sulfide	550,000		
	moderate	ABS, 20% glass fill	650,000	Delta PT fastener, twin helix Plastite 48 fastener, or PT fastener
Polyamide 66, 12% glass fill		800,000		
Polycarbonate, 20% glass fill (PC20)		850,000		
stiff	Polycarbonate, 30% glass fill (PC30)	1,100,000	Delta PT fastener, single-helix Plastite 48 or 45 fastener, or PT fastener	
	Polybutylene Terephthalates 30% glass fill (PBT30)	1,100,000		
	Polyamide 66, 30% glass fill (PA30)	1,200,000		
	Liquid Crystal Polymer (LCP)	1,400,000		
THERMOSETS	Polyphenylene Sulfide, 40% fill (PPS40)	1,700,000	Duro-PT® thread-cutting fastener	
	Phenolic, 20% glass fill	1,750,000		
	Polyester, 50% glass fill	2,100,000		

TYPE OF APPLICATION		FASTENING SOLUTION
ALL PLASTICS	Plastic or other materials to thin metal	Powergrip® fasteners
	Molded assemblies	PlasTORX® fasteners
	Extremely thin materials where a nut member is required	Perma-Nut® inserts
	Rapid assembly of plastic and/or metal components	RivscREW® threaded rivets

DELTA PT® THREAD-FORMING FASTENERS

Delta PT® fasteners are engineered to provide maximum performance in a wide range of thermoplastics. The improved design results in a stronger fastener that creates optimal material flow during installation, providing higher performance, better clamp loads and increased joint life.



SPECIFICATIONS

Sizes • Delta PT 14 – 70 (1.4mm – 7.0mm); other sizes under development

Head Styles • Can be used with any head design

Specials • Shoulder screws, sems, double end studs, collar studs; others as required

Drive Systems • TORX PLUS® Drive is recommended to facilitate the proper amount of torque transfer required for forming threads. Other styles also available.

APPLICATIONS

Thermoplastics with a flexural modulus up to 1,400,000 p.s.i.

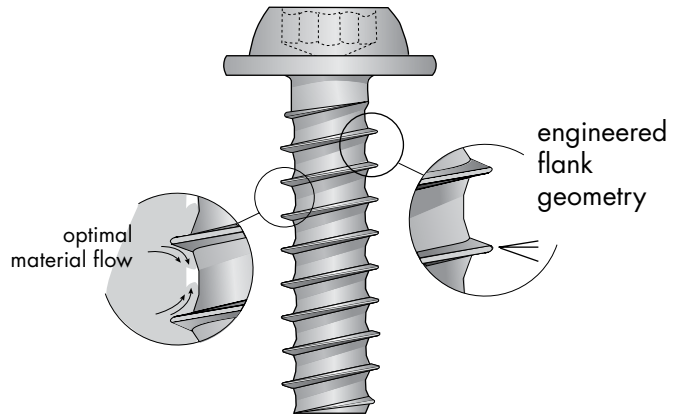

Delta PT Fastener

KEY ADVANTAGES

- Provides optimal performance in all types of thermoplastics
- Provides increased torsional and tensile strength over PT fasteners
- Provides high strength and in-place reliability
- Can achieve higher clamp loads and seating torques

FEATURES & BENEFITS

Flank geometry engineered to provide better material flow during installation

- Provides high flank engagement
- Can achieve higher clamp loads and seating torques
- Optimizes material flow
- May permit use of shorter fasteners and/or smaller diameters, if necessary

Larger fastener cross-section

- Increases shear area and fastener strength
- Offers increased fatigue life
- Provides increased torsional and tensile strength

Optimized pitch

- Allows high clamp load with smaller contact pressure
- Minimizes radial stress

DELTA PT® THREAD-FORMING FASTENERS

DIMENSIONAL DATA

*PT fastener standards are true metric sizes.

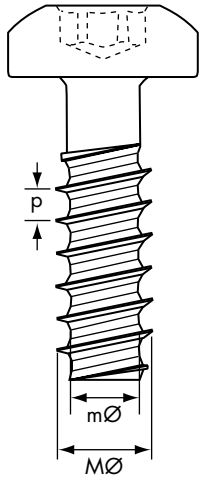

Nom. Size	Metric Size	p Thread Pitch (mm)	MØ Major Dia. (mm)	mØ Minor Dia. (mm)
Delta PT 14	M1.4	0.573	1.4	0.928
Delta PT 16	M1.6	0.641	1.6	1.073
Delta PT 18	M1.8	0.709	1.8	1.218
Delta PT 20	M2.0	0.78	2.0	1.4
Delta PT 22	M2.2	0.85	2.2	1.5
Delta PT 25	M2.5	0.95	2.5	1.7
Delta PT 30	M3.0	1.12	3.0	2.1
Delta PT 35	M3.5	1.29	3.5	2.5
Delta PT 40	M4.0	1.46	4.0	2.8
Delta PT 45	M4.5	1.63	4.5	3.2
Delta PT 50	M5.0	1.80	5.0	3.5
Delta PT 60	M6.0	2.14	6.0	4.3
Delta PT 70	M7.0	2.48	7.0	5.0

INCREASED STRENGTH

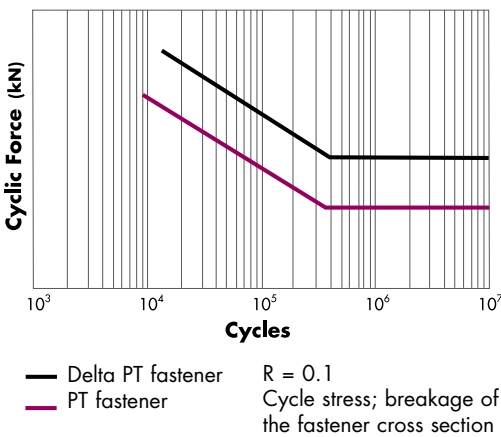

With its extended core diameter and optimum thread design, the Delta PT fastener offers a longer fatigue life than the PT fastener. The Delta PT design provides better thread engagement and, therefore, better conditions against stress fractures of the thread flank.

The chart above demonstrates that the Delta PT fastener provides greater resistance against screw breakage than the PT fasteners under in-service loads.

BOSS DESIGN RECOMMENDATIONS

The criteria for optimum hole diameter is to obtain the maximum clamp load during the installation process. A good starting point in determining the proper hole diameter is

$$d = 0.8 \times d_1$$

Specific applications will require some modifications to allow for the flexural modulus of the material, molding conditions, mold tool design, feed distance from gate, weld lines, structural heterogeneity and amount of reground material.

In order to ensure optimal performance, we recommend testing on initial samples. Please contact a Textron Fastening Systems applications engineer for assistance.

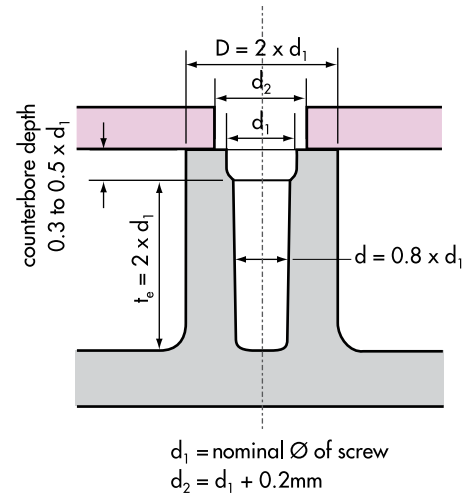

PT[®] THREAD-FORMING FASTENERS

With a high thread profile and recessed thread root, the PT fastener provides **increased thread engagement** with minimal stress on the boss. It provides **optimal performance** in a wide range of thermoplastics.

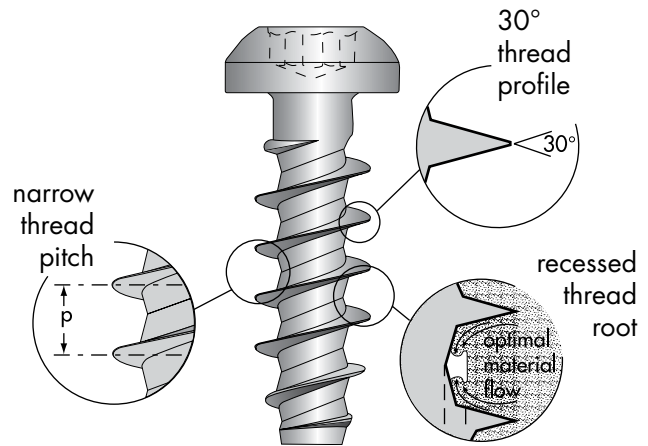

PT Fastener

KEY ADVANTAGES

- Optimizes performance in all types of thermoplastics
- Provides maximum resistance to back-out and pull-out
- Minimizes boss failure
- Increases product reliability

FEATURES & BENEFITS

Narrow 30° thread profile minimizes radial expansion and stress in boss

- Permits use of thinner bosses, which can reduce cycling times and material usage
- Reduces back-out caused by relaxation
- Increases load-carrying capability through increased thread engagement
- Can be used in repeat assembly operations

Optimum thread pitch allows deeper thread engagement

- Provides increased pull-out values
- Optimizes non-reversibility
- Balances load ratio between plastic and screw

Recessed thread root allows optimal material flow

- Minimizes installation torque
- Improves clamp load
- Minimizes potential of boss cracking

Round body evenly distributes surface contact between application and screw

- Improves load ratio
- Reduces high points of stress on the boss

Through hardened to Rc 33-39



SPECIFICATIONS

Sizes • K15 – K100 in diameter
up to 127mm under head

Head Styles • Can be used with any head design

Specials • Shoulder screws, sems, double end studs, collar studs; others as required

Drive Systems • TORX PLUS[®] Drive is recommended to facilitate the proper amount of torque transfer required for forming threads. Other styles also available.

APPLICATIONS

Thermoplastics with a flexural modulus up to 1,400,000 p.s.i.

PT® THREAD-FORMING FASTENERS

DIMENSIONAL DATA

*PT fastener standards are true metric sizes.

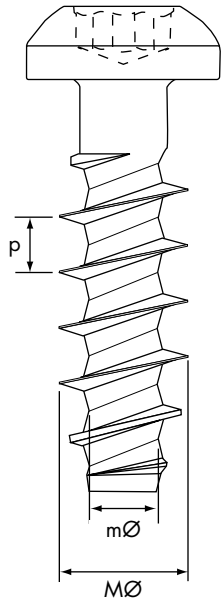

Nom. Size	Metric Size	p Thread Pitch (mm)	MØ Major Diameter (mm)	mØ Minor Diameter (mm)
K15	M1.5	0.67	1.50	0.89
K18	M1.8	0.80	1.80	1.04
K22	M2.2	0.98	2.20	1.25
K25	M2.5	1.12	2.50	1.40
K30	M3.0	1.34	3.00	1.66
K35	M3.5	1.57	3.50	1.91
K40	M4.0	1.79	4.00	2.17
K50	M5.0	2.24	5.00	2.68
K60	M6.0	2.69	6.00	3.19
K70	M7.0	3.14	7.00	3.70
K100	M10.0	4.49	10.00	5.23

HOLE SIZES PER PERCENTAGE OF THREAD ENGAGEMENT

Size	100%		90%		80%		70%		60%		50%		40%	
	mm	in.	mm	in.	mm	in.	mm	in.	mm	in.	mm	in.	mm	in.
K15	1.21	.048	1.24	.049	1.27	.050	1.30	.051	1.33	.052	1.35	.053	1.38	.054
K18	1.40	.055	1.44	.057	1.48	.058	1.52	.060	1.56	.061	1.60	.063	1.64	.065
K22	1.66	.065	1.71	.067	1.77	.070	1.82	.072	1.88	.074	1.93	.076	1.98	.078
K25	1.85	.073	1.92	.076	1.98	.078	2.05	.081	2.11	.083	2.18	.086	2.24	.088
K30	2.18	.086	2.26	.089	2.34	.092	2.42	.095	2.51	.099	2.59	.102	2.67	.105
K35	2.50	.098	2.60	.102	2.70	.106	2.80	.110	2.90	.114	3.00	.118	3.10	.122
K40	2.82	.111	2.94	.116	3.06	.120	3.17	.125	3.29	.130	3.41	.134	3.53	.139
K50	3.46	.136	3.62	.142	3.77	.148	3.92	.155	4.08	.161	4.23	.167	4.39	.173
K60	4.11	.162	4.30	.169	4.49	.177	4.68	.184	4.86	.192	5.05	.199	5.24	.206
K80	5.40	.212	5.66	.223	5.92	.233	6.18	.243	6.44	.253	6.70	.264	6.96	.274
K100	6.68	.263	7.02	.276	7.35	.289	7.68	.302	8.01	.315	8.34	.328	8.67	.341

PT® THREAD-FORMING FASTENERS

Laboratory testing and service applications have produced the general recommendations shown here. Specific applications may, however, require some modifications to allow for:

- molding conditions
- weld lines
- mold tool design
- structural heterogeneity
- amount of reground material
- feed distance from gate

In order to ensure optimal performance, we strongly recommend testing on initial samples.

COUNTERBORE SIZE

The width of the counterbore should be equal to the major diameter of the screw (d). The height of the counterbore should be 0.3 to 0.5 times the nominal screw diameter.

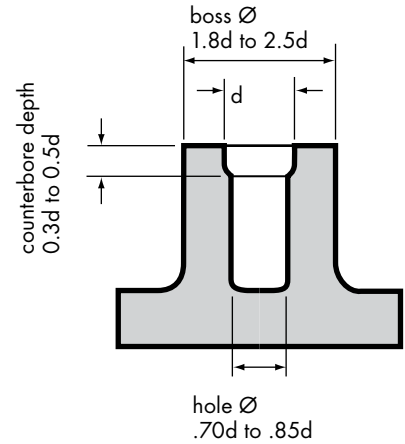

PT FASTENER BOSS DESIGN RECOMMENDATIONS

Material	Hole Diameter	Boss Diameter	Length of Engagement
ABS (acrylonitrile)	0.80 x d	2.00 x d	2.00 x d
ASA (acrylonitrile styrene acrylic)	0.78 x d	2.00 x d	2.00 x d
Nylon: PA6 (polyamide)	0.75 x d	1.85 x d	1.70 x d
Nylon: PA-GF30	0.80 x d	2.00 x d	1.90 x d
Nylon: PA6.6	0.75 x d	1.85 x d	1.70 x d
Nylon: PA6.6-GF30	0.82 x d	2.00 x d	1.80 x d
PBT (polybutylene terephthalate)	0.75 x d	1.85 x d	1.70 x d
PBT-GF30	0.80 x d	1.80 x d	1.70 x d
PC (polycarbonate)	0.85 x d	2.50 x d	2.20 x d
PC-GF30	0.85 x d	2.20 x d	2.00 x d
PE soft (polyethylene)	0.70 x d	2.00 x d	2.00 x d
PE hard (polyethylene)	0.75 x d	1.80 x d	1.80 x d
PET (polyethylene terephthalate)	0.75 x d	1.85 x d	1.70 x d
PET-GF30	0.80 x d	1.80 x d	1.70 x d
POM acetal	0.75 x d	1.95 x d	2.00 x d
PP (polypropylene)	0.70 x d	2.00 x d	2.00 x d
PPO (polyphenylene oxide)	0.85 x d	2.50 x d	2.20 x d
PS (polystyrene)	0.80 x d	2.00 x d	2.00 x d
PVC hard (polyvinyl chloride)	0.80 x d	2.00 x d	2.00 x d
SAN (styrene acrylonitrile)	0.77 x d	2.00 x d	1.90 x d

BOSS DESIGN EXAMPLE

Material: ABS

To calculate boss size based on fastener size:

Screw size: K40

Major diameter: 4mm

Boss O.D. = 2 X screw dia.

2 X 4mm = 8mm

Boss I.D. = .8 X screw dia.

.8 X 4mm = 3.2mm

Min. length of eng. = 2 X screw dia.

2 X 4mm = 8mm

To calculate screw size based on (predetermined) boss size:

Boss O.D.: 8mm

Boss I.D.: 3.2mm

Screw dia. = Boss O.D. ÷ 2

8mm ÷ 2 = 4mm

DST THREAD-FORMING FASTENERS

The high thread height and wide thread spacing of the DST (Dual-Spaced Thread) fastener allows **increased thread engagement** in softer thermoplastics, **increasing resistance to pull-out** and improving product performance.

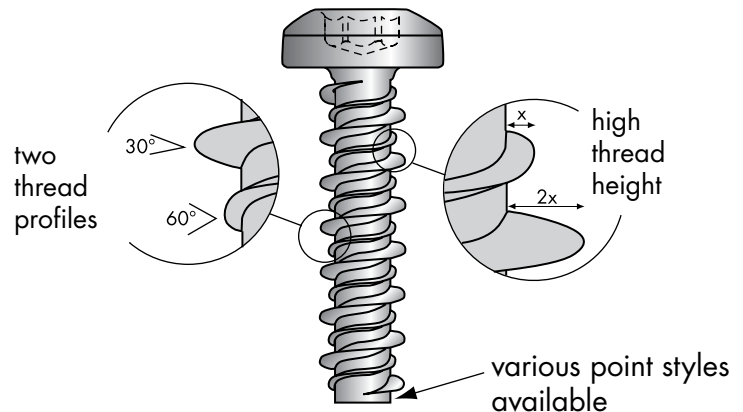

DST Fastener

KEY ADVANTAGES

- Performs well in softer thermoplastics

FEATURES & BENEFITS

High thread with a 30° flank angle to reduce radial stress in the boss

- Requires lower driving torque
- Reduces cracking of boss
- Allows use of smaller bosses

Smaller minor diameter than standard screws allows greater shear area

- Increases thread engagement
- Increases resistance to pull-out

Shank slot for thread-cutting can be added. Please contact a Textron Fastening Systems applications engineer for appropriate dimensional information.



SPECIFICATIONS

Sizes • #2 to 5/16 (M2.5 – M8.0)

Head Styles • Pan, hex, flat, oval, hex washer

Point Styles • Blunt, gimlet, pilot

Drive Systems • Can use any system, including TORX PLUS® Drive

APPLICATIONS

Thermoplastics with a flexural modulus up to 600,000 p.s.i.

DST THREAD-FORMING FASTENERS

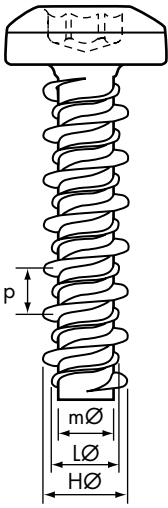

DIMENSIONAL DATA – INCH

Screw Size	p Thd. Pitch (per in.)	HØ High Thd. Dia.	LØ Low Thd. Dia.	mØ Ref. Minor Dia.
#5	20	.119 - .125	.100	.073
#6	19	.135 - .145	.108	.080
#7	19	.148 - .158	.130	.090
#8	18	.160 - .170	.130	.095
#10	16	.185 - .195	.145	.105
#12	16	.210 - .220	.167	.125
#13	16	.220 - .230	.180	.132
1/4"	15	.250 - .260	.200	.165
9/32"	16	.275 - .285	.230	.188
5/16"	14	.307 - .317	.250	.208

DIMENSIONAL DATA – METRIC

Screw Size	P Thd. Pitch	HØ High Thd. Dia.	LØ Low Thd. Dia.	mØ Ref. Minor Dia.
3.5	1.34	3.43 - 3.68	2.74	2.0
4.0	1.34	3.76 - 4.01	3.30	2.3
4.2	1.41	4.06 - 4.32	3.30	2.4
4.8	1.59	4.70 - 4.95	3.68	2.6
5.3	1.59	5.03 - 5.33	3.81	2.9
5.5	1.59	5.33 - 5.59	4.24	3.5
6.0	1.59	5.84 - 6.10	4.83	3.7
6.3	1.69	6.35 - 6.60	5.08	4.2
7.2	1.59	6.98 - 7.24	5.84	4.8
7.5	1.59	7.24 - 7.49	6.10	5.1
8.0	1.81	7.80 - 6.35	6.35	5.3

BOSS DESIGN RECOMMENDATIONS

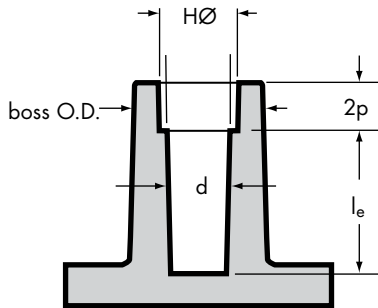

The recommended hole size (d) can be found in the chart to the right.

The length of engagement (l_e) should be 3 times the high thread diameter (see chart above).

Counterbore depth is 1 to 2 times the thread pitch length (see chart above). Counterbore depth is equal to the high thread diameter (HØ).

The boss O.D. should be at least 2 times the high thread diameter.

RECOMMENDED HOLE SIZES

Screw Size (inch)	Hole Size (d) (in)	Screw Size (metric)	Hole Size (d) (mm)
#5	.099	3.5	2.79
#6	.110	4.0	3.17
#7	.125	4.2	3.26
#8	.128	4.8	3.65
#10	.144	5.3	3.96
#12	.166	5.5	4.21
#13	.180	6.0	4.85
1/4"	.201	6.3	5.10
9/32"	.234	7.2	5.95
5/16"	.250	7.5	6.14
		8.0	6.35

NOTE: Recommended hole sizes for DST thread-cutting fasteners are not shown. Please contact a Textron Fastening Systems applications engineer for assistance.

PLASTITE® 48 THREAD-FORMING FASTENER

The Plastite® 48 fastener combines a unique tri-lobular body with a 48° thread profile to **maximize performance and reliability**. Two thread-forming styles are available to meet the specific requirements of a wide range of thermoplastics.

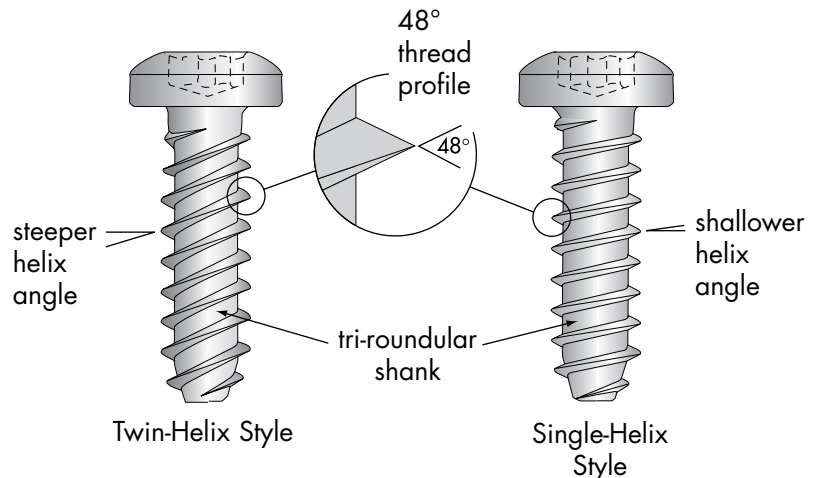

SPECIFICATIONS

Sizes • #00 – 5/16"; other sizes may be available upon request

Head Styles • Can be used with any external or internal head designs; pan, hex washer, and flat styles standard

Drive System • Can use any system, including TORX PLUS Drive

Finish • As required

APPLICATIONS

Twin Helix Style • Thermoplastics with a flexural modulus up to 850,000 p.s.i.

Single Helix Style • Thermoplastics with a flexural modulus between 850,000 p.s.i. and 1,400,000 p.s.i.

Plastite 48 Fasteners

KEY ADVANTAGES

- Reduces possibility of boss failure
- Increases product reliability
- Eliminates need for inserts and lock washers

FEATURES & BENEFITS

Tri-roundular configuration allows displaced material to cold flow back into relief areas

- Minimizes radial stress
- Reduces possibility of boss failure
- Eliminates need for inserts and lock washers
- Allows design of thinner bosses

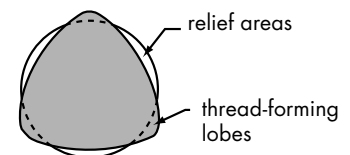

48° thread profile allows threads to penetrate deeply into plastic material

- Generates strong mating threads
- Resists vibration loosening
- Reduces probability of strip-out and pull-out

Twin lead design and steep helix angle provides greater shear area in softer plastics (with a flexural modulus up to 850,000 p.s.i.)

- Increases holding power
- Allows faster seating of fastener

Single lead design and narrow helix angle lowers drive torque and failure torque in stiffer thermoplastics (with flexural modulus between 850,000 and 1,300,000 p.s.i.)

- Creates less stress on the boss

PLASTITE® 48 THREAD-FORMING FASTENER

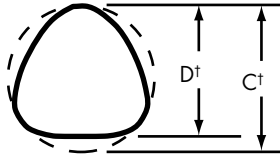

†C dimension measured with Tri-Flute Micrometer

D diameter measured with Standard Micrometer

DIMENSIONAL DATA – INCH SIZES

Nom. Size	Thread Pitch (per inch)	C Dimension max-min (in)	D Dimension max-min (in)	Screw Length Tolerance	
				under 3/4" (in)	over 3/4" (in)
#00	51	.0496 - .0466	.0475 - .0445	±.015	±.015
#0	42	.0665 - .0635	.0635 - .0605	±.015	±.015
#1	32	.081 - .078	.078 - .075	±.030	±.030
#2	28	.092 - .086	.089 - .083	±.030	±.030
#3	24	.110 - .104	.106 - .100	±.030	±.030
#4	20	.127 - .121	.123 - .117	±.030	±.050
#6	19	.147 - .141	.143 - .137	±.030	±.050
#7	18	.166 - .160	.160 - .154	±.030	±.050
#8	16	.185 - .179	.179 - .173	±.030	±.050
#9	15	.199 - .193	.193 - .187	±.030	±.050
#10	14	.212 - .206	.208 - .202	±.030	±.050
#12	14	.232 - .226	.226 - .220	±.030	±.050
1/4"	10	.276 - .270	.268 - .262	±.050	±.050
5/16"	9	.345 - .335	.335 - .325	±.050	±.050

DIMENSIONAL DATA – METRIC SIZES*

*soft converted metric sizes

Nom. Size	Thread Pitch	C Dimension max-min (mm)	D Dimension max-min (mm)	Screw Length Tolerance	
				under 19.05mm (mm)	over 19.05mm (mm)
1.12	0.50	1.26 - 1.18	1.21 - 1.13	±0.38	±0.38
1.59	0.60	1.69 - 1.61	1.61 - 1.54	±0.38	±0.38
1.91	0.79	2.06 - 1.98	1.98 - 1.91	±0.76	±0.76
2.26	0.91	2.34 - 2.18	2.26 - 2.11	±0.76	±0.76
2.63	1.06	2.79 - 2.64	2.69 - 2.54	±0.76	±0.76
3.12	1.27	3.23 - 3.07	3.12 - 2.97	±0.76	±1.27
3.63	1.34	3.73 - 3.58	3.63 - 3.48	±0.76	±1.27
4.06	1.41	4.22 - 4.06	4.06 - 3.91	±0.76	±1.27
4.55	1.59	4.70 - 4.55	4.55 - 4.39	±0.76	±1.27
4.90	1.69	5.05 - 4.90	4.90 - 4.75	±0.76	±1.27
5.28	1.81	5.38 - 5.23	5.28 - 5.13	±0.76	±1.27
5.74	1.81	5.89 - 5.74	5.74 - 5.59	±0.76	±1.27
6.81	2.54	7.01 - 6.86	6.81 - 6.65	±1.27	±1.27
8.51	2.82	8.76 - 8.51	8.51 - 8.26	±1.27	±1.27

* Plastite 48 fasteners are not available in true metric sizes. The chart above provides nominal inch dimensions converted to millimeters.

PLASTITE® 48 THREAD-FORMING FASTENER

HOLE SIZES PER PERCENTAGE OF THREAD ENGAGEMENT

Size	100%		90%		80%		70%		60%		50%		40%	
	in.	mm	in.	mm	in.	mm	in.	mm	in.	mm	in.	mm	in.	mm
#00-51	.0377	0.957	.0386	0.980	.0395	1.003	.0404	1.026	.0413	1.049	.0423	1.074	.0432	1.097
#0-42	.0498	1.265	.0510	1.295	.0523	1.328	.0535	1.359	.0548	1.392	.0560	1.422	.0573	1.455
#1-32	.0621	1.577	.0632	1.605	.0646	1.641	.0658	1.671	.0671	1.704	.0683	1.735	.0695	1.765
#2-28	.0743	1.887	.0757	1.923	.0771	1.958	.0785	1.994	.0799	2.029	.0813	2.065	.0827	2.101
#3-24	.0855	2.172	.0873	2.217	.0890	2.261	.0908	2.306	.0925	2.350	.0943	2.395	.0960	2.438
#4-20	.0970	2.464	.1000	2.540	.1020	2.591	.1050	2.667	.1070	2.718	.1100	2.794	.1130	2.870
#6-19	.1180	2.997	.1200	3.048	.1230	3.124	.1250	3.175	.1280	3.251	.1300	3.302	.1320	3.353
#7-18	.1370	3.480	.1390	3.531	.1420	3.607	.1440	3.657	.1460	3.708	.1490	3.785	.1510	3.835
#8-16	.1440	3.658	.1480	3.759	.1510	3.835	.1550	3.937	.1580	4.013	.1620	4.115	.1650	4.191
#9-15	.1570	3.988	.1590	4.039	.1610	4.089	.1640	4.166	.1660	4.216	.1680	4.267	.1700	4.318
#10-14	.1700	4.318	.1740	4.420	.1770	4.496	.1810	4.597	.1850	4.699	.1890	4.801	.1920	4.877
#12-14	.1880	4.775	.1920	4.877	.1960	4.978	.1990	5.055	.2030	5.156	.2070	5.258	.2110	5.359
1/4"-10	.2180	5.537	.2230	5.664	.2280	5.791	.2330	5.918	.2380	6.045	.2430	6.172	.2480	6.299
5/16"-9	.2840	7.214	.2910	7.391	.2980	7.569	.3050	7.747	.3110	7.899	.3180	8.077	.3250	8.255

BOSS DESIGN RECOMMENDATIONS

The length of engagement (L) should be 2 to 3 times the fastener's C dimension. Testing should be done to determine optimal thread engagement on any application with a lower length of engagement.

The nominal hole size ($h\emptyset$) must be established based on the amount of thread engagement (see chart above). For optimum performance, the hole size should provide a minimum 70% thread engagement.

The outside diameter of the boss (boss O.D.) should be 2.5 to 3 times the nominal diameter of the screw (C dimension). The boss height should not exceed 2 times the boss O.D.

The counterbore width (CB_w) should be slightly larger than the C dimension. Its depth (CB_d) should be 1/4 to 1/2 the thread pitch.

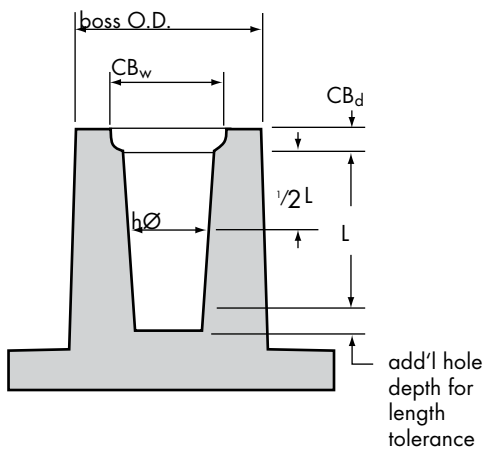

PLASTITE® 45 THREAD-FORMING FASTENER

The Plastite® 45 fastener is designed to facilitate thread-forming in less-compressible plastics while providing **high resistance to strip-out and pull-out**. It has smaller root and major diameters than a 48° Plastite, so it can be used in smaller bosses.

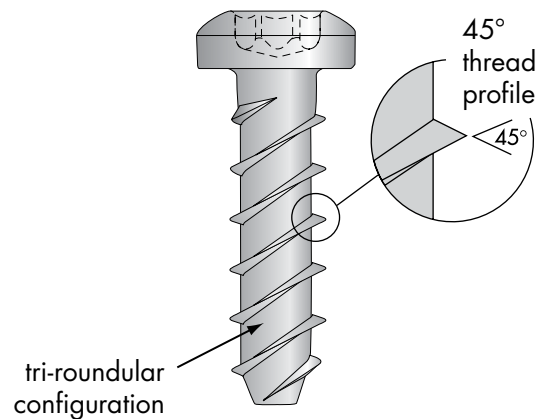

Plastite® 45 Fastener



SPECIFICATIONS

Sizes • #2 – 3/8" (metric sizes 2 – 8); other sizes may be available upon request

Head Styles • Can be used with any external or internal head designs; pan, hex washer, and flat styles standard

Drive System • Can use any system, including TORX PLUS® Drive

Finish • As required

APPLICATIONS

Engineering-grade thermoplastics (with a flexural modulus over 850,000 p.s.i.)

KEY ADVANTAGES

- Can be used in smaller bosses than Plastite 48 fasteners
- Increases product reliability
- Lowers required drive torque when fastening stiffer thermoplastics

FEATURES & BENEFITS

Tri-roundular configuration allows displaced material to cold flow back into relief areas

- Minimizes radial stress
- Reduces possibility of boss failure
- Eliminates need for inserts and lock washers
- Allows design of thinner bosses

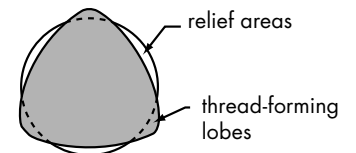

45° thread profile allows threads to penetrate deeply into plastic material

- Generates strong mating threads
- Resists vibration loosening
- Increases resistance to strip-out
- Achieves wide differentials between drive and fail torque

Single lead design and narrow helix angle lowers drive torque and failure torque in thermoplastics with a flexural modulus over 850,000 p.s.i.

- Creates less stress on the boss

PLASTITE® 45 THREAD-FORMING FASTENER

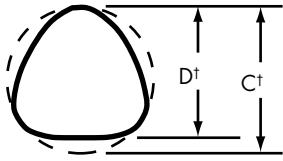

† C dimension measured with Tri-Flute Micrometer
D diameter measured with Standard Micrometer

DIMENSIONAL DATA – INCH SIZES

Nom. Size	Thread Pitch (per inch)	C Dimension max-min (in)	D Dimension max-min (in)	Screw Length Tolerance	
				under 3/4" (in)	over 3/4" (in)
#2	19	.0875 - .0835	.0845 - .0805	± .030	±.050
#3	18	.101 - .097	.098 - .094	± .030	±.050
#4	17	.1145 - .1095	.111 - .106	± .030	±.050
#5	15	.1275 - .1225	.1235 - .1185	± .030	±.050
#6	13	.141 - .136	.137 - .132	± .030	±.050
#7	12	.153 - .148	.1485 - .1435	± .030	±.050
#8	11	.167 - .161	.162 - .156	± .030	±.050
#9	10	.179 - .173	.174 - .168	± .030	±.050
#10	9	.194 - .188	.189 - .183	± .030	±.050
#12	9	.220 - .214	.2145 - .2085	± .030	±.050
1/4"	8	.253 - .247	.247 - .241	±.050	±.050
9/32"	8	.284 - .278	.278 - .272	±.050	±.050
5/16"	8	.316 - .308	.309 - .301	±.050	±.050
21/64"	8	.332 - .324	.325 - .317	±.050	±.050
11/32"	8	.349 - .341	.342 - .334	±.050	±.050
3/8"	7	.379 - .371	.371 - .363	±.050	±.050

DIMENSIONAL DATA – METRIC SIZES

Nom. Size	Thread Pitch	C Dimension max-min (mm)	D Dimension max-min (mm)	Screw Length Tolerance	
				under 20mm (mm)	over 20mm (mm)
2	1.35	2.04 - 1.92	1.99 - .0783	±.08	±1.3
2.5	1.4	2.53 - 2.41	2.49 - 2.37	±.08	±1.3
3	1.5	3.04 - 2.92	2.99 - 2.87	±.08	±1.3
3.5	1.65	3.54 - 3.42	3.48 - 3.34	±.08	±1.3
4	1.75	4.04 - 3.89	3.94 - 3.79	±.08	±1.3
4.5	2.0	4.54 - 4.39	4.43 - 4.28	±.08	±1.3
5	2.2	5.04 - 4.89	4.94 - 4.79	±1.3	±1.3
5	2.3	5.04 - 4.89	4.94 - 4.79	±1.3	±1.3
6	2.5	6.04 - 5.89	5.93 - 5.78	±1.3	±1.3
8	3	8.04 - 7.86	7.89 - 7.71	±1.3	±1.3

PLASTITE® 45 THREAD-FORMING FASTENER

HOLE SIZES PER PERCENTAGE OF THREAD ENGAGEMENT

Inch Sizes	100% (in.)	90% (in.)	80% (in.)	70% (in.)	60% (in.)
2-19	.065	.067	.069	.071	.073
3-18	.076	.078	.081	.083	.085
4-17	.087	.090	.093	.095	.098
5-15	.099	.102	.104	.107	.110
6-13	.101	.105	.109	.112	.116
7-12	.112	.116	.120	.124	.128
8-11	.125	.129	.133	.137	.141
9-10	.131	.136	.141	.145	.150
10-9	.148	.152	.157	.161	.166
12-9	.167	.172	.177	.182	.187
1/4-8	.196	.202	.207	.213	.219
9/32-8	.221	.227	.233	.239	.245
5/16-8	.251	.257	.264	.270	.276
21/64-8	.265	.271	.278	.284	.291
11/32-8	.281	.288	.294	.301	.307
3/8-7	.302	.310	.317	.325	.332

Metric Sizes	100% (mm)	90% (mm)	80% (mm)	70% (mm)	60% (mm)
2 x 1.35	1.36	1.41	1.46	1.51	1.57
2.5 X 1.4	1.78	1.83	1.88	1.94	2.00
3 X 1.5	2.25	2.30	2.37	2.43	2.50
3.5 X 1.65	2.68	2.74	2.80	2.88	2.95
4 X 1.75	3.11	3.18	3.25	3.33	3.41
5 X 2.2	3.70	3.80	3.91	4.03	4.16
5 X 2.3	3.67	3.76	3.86	3.98	4.10
6 X 2.5	4.57	4.68	4.79	4.91	5.05
8 X 3.0	6.36	6.49	6.62	6.77	6.92

BOSS DESIGN RECOMMENDATIONS

The length of engagement (L) should be 2 to 3 times the fastener's C dimension. Testing should be done to determine optimal thread engagement on any application with a lower length of engagement.

The nominal hole size ($h\emptyset$) must be established based on the amount of thread engagement (see chart above). For optimum performance, the hole size should provide a minimum 70% thread engagement.

The outside diameter of the boss (boss O.D.) should be 2.5 to 3 times the nominal diameter of the screw (C dimension). The boss height should not exceed 2 times the boss O.D.

The counterbore width (CB_w) should be slightly larger than the C dimension. Its depth (CB_d) should be 1/4 to 1/2 the thread pitch.

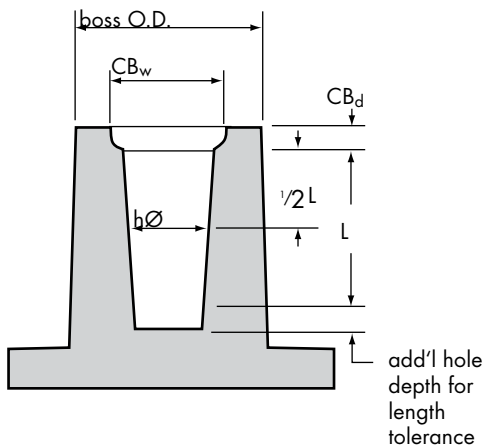

DURO-PT® THREAD-CUTTING FASTENERS

The Duro-PT® thread-cutting fastener is engineered to meet the demanding requirements of thermoset plastics, **easing assembly** and **ensuring a strong, reliable joint** to maximize assembly performance.

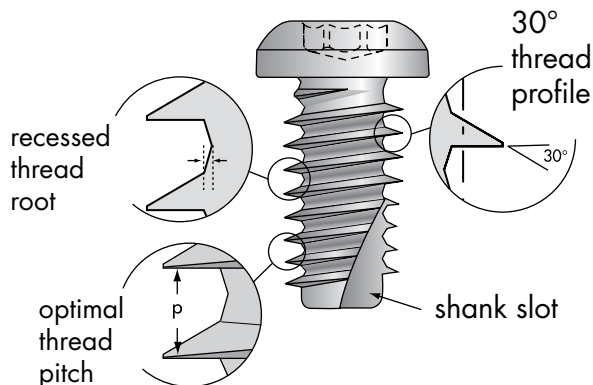

Duro-PT® Thread-Cutting Fastener

KEY ADVANTAGES

- Cuts threads in stiffer plastics
- Minimizes installation torque
- Maximizes assembly performance

FEATURES & BENEFITS

Asymmetrical 30° thread profile, inclined towards load surface to increase friction (FR) between the application and the fastener

- Reduces radial stress
- Reduces back-out caused by relaxation
- Increases strip resistance
- Eliminates need for supplementary locking devices

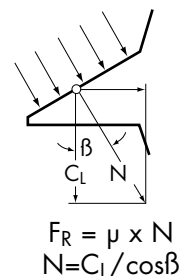

Optimal thread pitch for deeper thread engagement

- Increases pull-out strength
- Increases resistance to vibration loosening
- Increases load-carrying capability

Recessed thread root provides space for displaced material

- Minimizes installation torque
- Minimizes risk of clogging and galling of threads during assembly

Shank slot minimizes chip production

Through hardened to Rc 33-39

SPECIFICATIONS

Sizes • S22 to S80 in diameter; up to 152mm under head. Other sizes may be available upon request.

Head Styles • Pan, flat, hex, round washer, hex washer, oval, button head, fillister

Specials • Shoulder screws, sems, double end studs, collar studs; others as required

Drive Systems • TORX PLUS® Drive System is recommended to facilitate the proper amount of torque transfer required for cutting threads. Other styles are available.

APPLICATIONS

Thermoset plastics

DURO-PT® THREAD-CUTTING FASTENERS

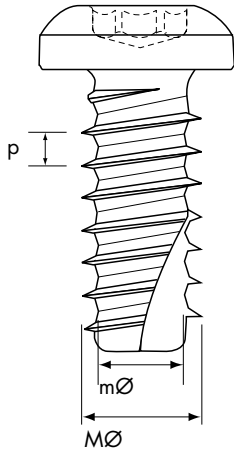

DIMENSIONAL DATA

Nom. Size	Metric Size	P Thread Pitch (mm)	MØ Major Diameter (mm)	mØ Minor Diameter (mm)
S22	M2.2	0.71	2.20	1.59
S25	M2.5	0.77	2.50	1.81
S30	M3	0.86	3.00	2.18
S35	M3.5	0.95	3.50	2.56
S40	M4	1.04	4.00	2.93
S50	M5	1.23	5.00	3.68
S60	M6	1.42	6.00	4.42
S70	M7	1.60	7.00	5.20
S80	M8	1.79	8.00	5.91

HOLE SIZES PER PERCENTAGE OF THREAD ENGAGEMENT

Size	100%		90%		80%		70%		60%		50%		40%	
	mm	in.	mm	in.	mm	in.	mm	in.	mm	in.	mm	in.	mm	in.
S22	1.71	.067	1.77	.070	1.83	.072	1.88	.074	1.94	.076	1.99	.078	2.05	.081
S25	1.95	.077	2.01	.079	2.07	.082	2.13	.084	2.20	.086	2.26	.089	2.32	.091
S30	2.34	.092	2.41	.095	2.48	.098	2.56	.101	2.63	.104	2.70	.106	2.78	.109
S35	2.73	.107	2.81	.111	2.90	.114	2.99	.118	3.07	.121	3.16	.124	3.24	.128
S40	3.12	.123	3.21	.127	3.31	.130	3.41	.134	3.51	.138	3.60	.142	3.70	.146
S50	3.90	.153	4.01	.158	4.13	.163	4.25	.167	4.37	.172	4.49	.177	4.61	.182
S60	4.67	.184	4.82	.190	4.96	.195	5.10	.201	5.24	.206	5.38	.212	5.52	.217
S70	5.45	.215	5.62	.221	5.78	.228	5.95	.234	6.12	.241	6.28	.247	6.45	.254
S80	6.23	.245	6.42	.253	6.61	.260	6.80	.268	6.98	.275	7.17	.282	7.36	.290

SUGGESTED THREAD ENGAGEMENT

Based on testing and past performance, a thread engagement of 50% to 60% is recommended. For optimal fastener performance, please contact a Textron Fastening Systems applications engineer. See following page for boss design recommendations.

DURO-PT® THREAD-CUTTING FASTENERS

BOSS DESIGN RECOMMENDATIONS

Laboratory testing and service applications have produced the general recommendations shown. Specific applications may, however, require some modification in order to allow for:

- molding conditions
- mold tool design
- type of resin
- type of filler
- material density

DETERMINING OPTIMUM BOSS & HOLE SIZES

A hole diameter of .85d to .89d is permissible for most thermoset applications. In order to properly determine boss and hole sizes, it is recommended that testing be done on several different hole sizes. This will allow you to determine the optimum drive-to-strip ratio that is required for your application.

BOSS HOLE DIAMETER (db)

d = nominal screw diameter

Size	.85d		.86d		.87d		.88d		.89d	
	mm	in.	mm	in.	mm	in.	mm	in.	mm	in.
S22	1.87	.074	1.89	.074	1.91	.075	1.94	.076	1.96	.077
S25	2.12	.083	2.15	.085	2.17	.085	2.20	.087	2.23	.088
S30	2.55	.100	2.58	.102	2.61	.103	2.64	.104	2.67	.105
S35	2.97	.117	3.01	.119	3.04	.120	3.08	.121	3.12	.123
S40	3.40	.134	3.44	.135	3.48	.137	3.52	.139	3.56	.140
S50	4.25	.167	4.30	.169	4.35	.172	4.40	.173	4.45	.175
S60	5.10	.201	5.16	.203	5.22	.206	5.28	.208	5.34	.210
S70	5.95	.234	6.02	.237	6.09	.240	6.16	.243	6.23	.245
S80	6.80	.268	6.88	.271	6.96	.274	7.04	.277	7.12	.280

BOSS OUTER DIAMETER (O.D.)

d = nominal screw diameter

Size	.85d		.86d		.87d		.88d		.89d	
	mm	in.	mm	in.	mm	in.	mm	in.	mm	in.
S22	6.38	.251	6.23	.245	6.09	.240	5.94	.234	5.79	.228
S25	7.25	.285	7.08	.279	6.92	.272	6.75	.266	6.58	.259
S30	8.70	.343	8.50	.335	8.30	.327	8.10	.319	7.90	.311
S35	10.15	.400	9.92	.391	9.68	.381	9.45	.372	9.21	.363
S40	11.60	.457	11.33	.446	11.07	.436	10.25	.425	10.53	.415
S50	14.50	.571	14.15	.557	13.83	.544	13.50	.531	13.17	.519
S60	17.40	.685	17.00	.669	16.60	.654	16.20	.638	15.80	.622
S70	20.30	.799	19.38	.781	19.37	.763	18.90	.744	18.43	.726
S80	23.20	.913	22.67	.893	22.13	.871	21.60	.850	21.07	.830

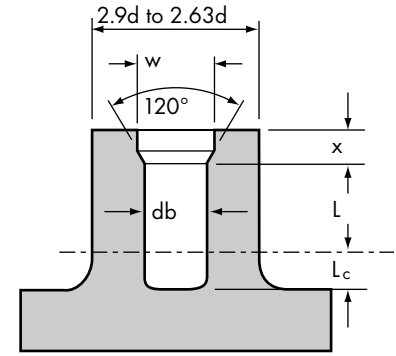

d = nominal screw diameter

BOSS COUNTERBORE SIZE

High tightening torques and large tensile stresses may cause a cone-shaped expansion and failure at the bottom of the boss. Designing the boss with the appropriate counterbore (CB) reduces edge stress and alleviates cracking.

CB depth: $x = 0.5d$
CB width: $w = 1.08 \times d$

LENGTH OF ENGAGEMENT

The length of engagement (L) should be 2 to 3 times the nominal screw diameter. This calculation should exclude counterbore depth.

CHIP SPACE DEPTH

The depth of space (L_c) for chips removed during thread cutting operations should be between 0.8 and 1.2 the nominal screw diameter.

POWERGRIP® FASTENERS FOR LAYERED ASSEMBLIES

Ideal for attaching soft materials, such as plastics and elastomers, to a single thickness of sheet metal, Powergrip® fasteners maintain the integrity of the soft material while providing resistance to strip-out and loosening.

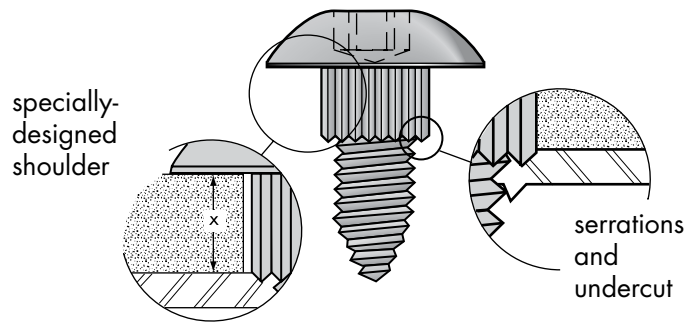

Powergrip Fastener



SPECIFICATIONS

Sizes • M3 – M8 (#4 – 3/8")

Thread Styles • Type CA threads are recommended for maximum thread engagement; others as required

Head Styles • Hex washer, pan, round, truss, hex

Drive Styles • TORX PLUS® Drive; also cross, slotted, and hex

APPLICATIONS

Soft materials such as plastic, rubber and elastomers to sheet metal

KEY ADVANTAGES

- Overcomes loosening in metal to plastic/elastomer applications
- Prevents soft material from being crushed during assembly
- Can be used in a variety of materials, soft or brittle, where there is a chance that cracking or crushing of the overlay material may occur

FEATURES & BENEFITS

Individually engineered to meet the unique requirements of each application

- Can be used in a variety of materials, soft or brittle, where there is a chance that cracking or crushing of the overlay material may occur

Specially designed shoulder designed to match the thickness of the soft material in each application

- Prevents soft material from being crushed during assembly

Serrations and a small undercut on the bottom of shoulder to decrease the distance between the last thread and the shoulder

- Increases thread engagement
- Increases strip-out resistance
- Prevents vibration loosening
- Increases torque resistance
- Provides tight, uniform joint

PLASTORX® FASTENERS FOR PLASTIC ASSEMBLIES

Developed to be molded into plastic and replace metal stamping and fastener assemblies, PlasTORX® studs are engineered to **provide high resistance to rotation and pull-out**, ensuring a high-performance assembly. Its hex-lobular design helps reduce stress risers, so it can be used in materials susceptible to cracking or breaking.

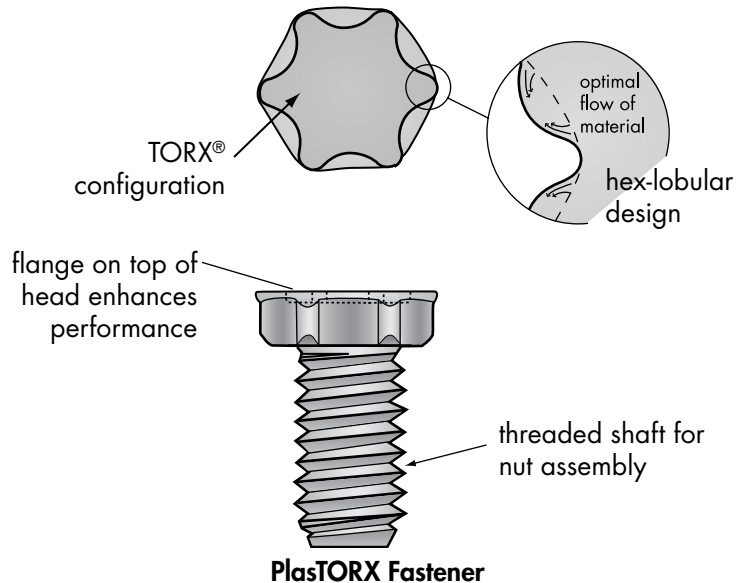

SPECIFICATIONS

Sizes • M4 – M12 (#8 - 1/2")

Lengths • Per customer design

Thread Styles • Machine screw;
others as specified

Specials • Completed assemblies
available

APPLICATIONS

Injection-molded thermoplastics and rubber

KEY ADVANTAGES

- Molded directly into application which increases assembly efficiency
- Provides maximum resistance to rotation and pull-out
- Can be used in materials susceptible to cracking

FEATURES & BENEFITS

Hex-lobular TORX® configuration allows deep lobe engagement

- Increases torsional resistance
- Increases pull-out resistance
- Reduces stress risers

Flange on top of head enhances performance

- Increases pull-out resistance

Threaded shaft for seating nut member

Designed to be molded directly into component or carrier strips, allowing multiple fasteners to be installed at one time

- Reduces assembly time
- Reduces part numbers and associated costs
- Reduces overall costs

PLASTORX® FASTENERS FOR PLASTIC ASSEMBLIES

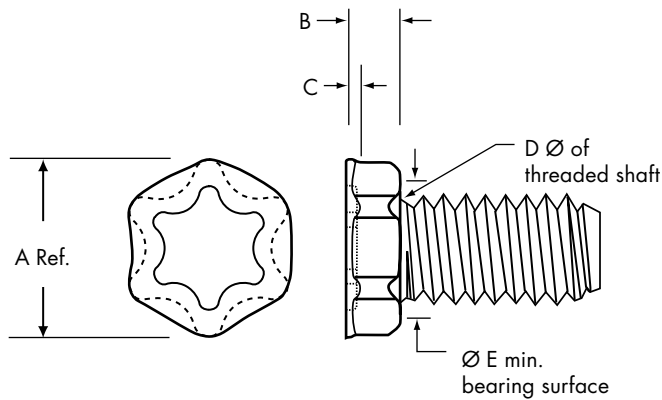

- Contour may vary between lobes within specified dimensions.
- Dimensions shown are for low carbon steel fasteners. For other materials or modified designs, contact a Textron Fastening Systems applications engineer.
- Performance is determined by application material.

DIMENSIONAL DATA – METRIC SIZES

Thread Size	A Ref.	B ±0.13	C ±0.25	D Max.	E Min.	Min. Molded Material Width	Min. Molded Material Height (B + 25%)
M4	9.19	1.84	0.50	0.8	6.30	12.41	2.30
M5	10.95	2.28	0.80	0.8	7.35	14.85	2.85
M6	14.50	3.00	0.80	0.8	10.00	20.25	3.75
M8	16.38	3.68	1.00	1.0	11.30	23.10	4.60
M10	19.99	4.88	1.00	1.0	15.75	28.50	6.10
M12	23.60	6.88	1.14	1.0	18.50	33.90	8.60

DIMENSIONAL DATA – INCH SIZES

Thread Size	A Ref.	B ±.005	C ±.010	D Max	E Min.	Min. Molded Material Width	Min. Molded Material Height (B + 25%)
#8	.362	.072	.030	.031	.248	.489	.090
#10	.431	.090	.041	.031	.289	.585	.113
1/4	.571	.118	.041	.031	.394	.797	.148
5/16	.645	.145	.049	.039	.445	.909	.181
3/8	.787	.192	.049	.039	.620	1.122	.240
1/2	.929	.271	.055	.039	.728	1.335	.339

PERMA-NUT™ INSERTS FOR THIN MATERIALS

Combining the functions of a semi-tubular rivet and a nut, Perma-Nut™ inserts provide an **economical and permanent threaded fitting** with minimal deformation of the application. They can be used in plastics, metals and composite materials.

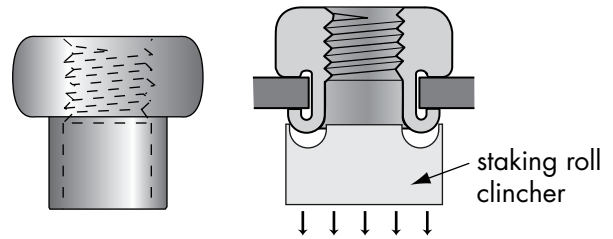

Perma-Nut Insert

KEY ADVANTAGES

- Can perform a variety of functions in thinner materials
- Permits efficient installation

FEATURES & BENEFITS

Semi-tubular rivet and nut with roll clinch set

Threads in nut head provide a more secure joint

Underhead serrations grip material

- Increases rotational resistance
- Increases reliability

Roll-clinch installation (requiring two sided access) for more efficient installation

- Automatic or semi-automatic multiple-station equipment, standard tooling or high-speed riveting can be used
- Allows multiple installation
- Lowers assembly costs

Can be used in materials as thin as 0.254mm (.010") and where low profiles are required

Highly versatile design to perform a variety of functions to meet the specific needs of your application

- Nut plate applications to eliminate installing nuts in hard-to-reach areas
- Nut and rivet applications
- Nut, rivet and spacer applications
- Nut and bushing applications

Initial testing is required to determine optimal roll crimp pressure for each application. Please contact a Textron Fastening Systems applications engineer for technical assistance.



SPECIFICATIONS

Internal Thread Sizes • M2 to M10 (#4 to 3/8"); special sizes available upon request

Materials • Low carbon steel, brass, aluminum

Finish • Zinc plate with chromate sealer; others as required

APPLICATIONS

Thermoset plastics that require a threaded fitting. Application testing is required to determine usability in thermoplastic materials.

PERMA-NUT™ INSERTS FOR THIN MATERIALS

DIMENSIONAL DATA, STANDARD SET – INCH SIZES

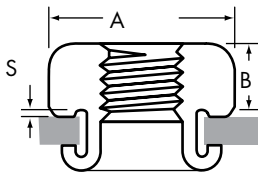
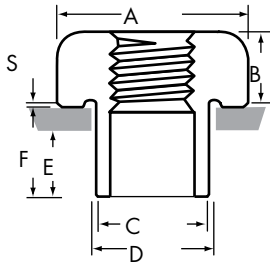

Standard Set

Thread Size	A	B	S	No. of Threads	C	D	E			F	
	Head Dia.	Head Ht.	Serr. Ht.				Min.	Nom.	Max	Min.	Max
4-40UNC-2B	.312	.093	.010	3-1/2 to 4	.158	.173	.072	.078	.083	.125	.313
5-40UNC-2B	.344	.109	.010	4 to 4-1/2	.189	.203	.085	.092	.098	.125	.375
6-32UNC-2B	.344	.109	.010	3-1/2 to 4	.189	.203	.085	.092	.098	.125	.375
8-32UNC-2B	.375	.125	.010	3-1/2 to 4	.227	.242	.106	.112	.118	.141	.500
10-24UNC-2B	.406	.125	.010	3 to 3-1/2	.250	.265	.115	.123	.130	.141	.500
10-32UNF-2B	.406	.125	.010	3-1/2 to 4	.250	.265	.115	.124	.132	.141	.500
1/4-20UNC-2B	.469	.174	.010	3 to 3-1/2	.328	.343	.156	.164	.172	.156	.625
1/4-28UNF-2B	.469	.174	.010	4 to 4-1/2	.328	.343	.156	.164	.172	.156	.625
5/16-18UNC-2B	.530	.250	.010	3 to 3-1/2	.421	.437	.203	.214	.224	.219	.625
5/16-24UNF-2B	.530	.250	.010	4 to 4-1/2	.421	.437	.203	.214	.224	.219	.625

DIMENSIONAL DATA, STANDARD SET – METRIC SIZES

Thread Size	A	B	S	No. of Threads	C	D	E			F	
	Head Dia.	Head Ht.	Serr. Ht.				Min.	Nom.	Max	Min.	Max
M2 X 0.4-6H	7.2	2.2	.254	3-1/2 to 4	3.6	4.01	1.67	1.78	1.88	3.2	9.5
M3 x 0.5-6H	8.7	2.8	.254	3-1/2 to 4	4.8	5.15	2.20	2.35	2.49	3.2	9.5
M4 x 0.7-6H	9.5	3.4	.254	3 to 3-1/2	5.8	6.14	2.64	2.82	2.99	3.6	12.7
M5 x 0.8-6H	10.8	3.5	.254	3 to 3-1/2	6.9	7.24	3.15	3.35	3.55	3.6	12.7
M6 x 1.0-6H	11.9	4.4	.254	3 to 3-1/2	8.3	8.71	3.83	4.07	4.31	4.0	15.9
M8 x 1.25-6H	13.5	6.1	.254	3 to 3-1/2	10.4	10.76	4.77	5.09	5.41	5.5	15.9
M10 x 1.50-6H	16.2	7.5	.254	4 to 4-1/2	12.4	12.77	5.69	6.07	6.45	5.5	20.6

To establish proper body length for a roll clinch, add the total compressed thicknesses of the work pieces to be assembled to the nominal clinch allowance given in the table for each body diameter. Additional sizes available upon request.

DIMENSIONAL DATA, FLUSH SET – INCH SIZES

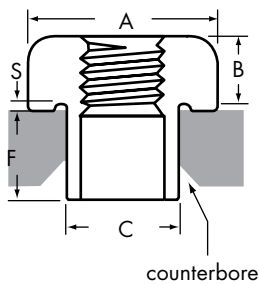

counterbore

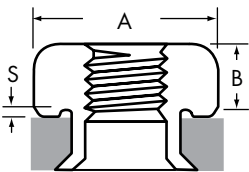

Flush Set

Thread Size	A	B	S	No. of Threads	C	D	Work Hole	
	Head Dia.	Head Height	Serr. Height				Min Length	Dia. Drill
4-40UNC-2B	.312	.109	.010	3-1/2 to 4	.189	.031	.191	#11
5-40UNC-2B	.344	.109	.010	3-1/2 to 4	.189	.031	.191	#11
6-32UNC-2B	.344	.125	.010	3-1/2 to 4	.212	.031	.215	#3
8-32UNC-2B	.375	.140	.010	3 to 3-1/2	.250	.062	.256	F-
10-24UNC-2B	.406	.177	.010	3 to 3-1/2	.281	.062	.287	L
10-32UNF-2B	.406	.177	.010	3 to 3-1/2	.281	.062	.287	L
1/4-20UNC-2B	.469	.208	.010	3 to 3-1/2	.375	.062	.380	V
1/4-20UNF-2B	.469	.208	.010	3 to 3-1/2	.375	.062	.380	V
5/16-18UNC-2B	.530	.240	.010	3 to 3-1/2	.421	.062	.428	27/64
5/16-24UNF-2B	.530	.240	.010	3 to 3-1/2	.421	.062	.428	27/64

DIMENSIONAL DATA, FLUSH SET – METRIC SIZES

Thread Size	A	B	S	No. of Threads	C	D	Work Hole	
	Head Dia.	Head Height	Serr. Height				Min Length	Dia. Drill
M2 x 0.4-6H	7.2	2.2	.254	3-1/2 to 4	3.6	0.8	3.73	26
M3 x 0.5-6H	8.7	2.8	.254	3-1/2 to 4	4.8	0.8	4.91	10
M4 x 0.7-6H	9.5	3.4	.254	3 to 3-1/2	5.8	1.6	5.80	1
M5 x 0.8-6H	10.8	3.5	.254	3 to 3-1/2	6.9	1.6	7.00	7mm
M6 x 1.0-6H	11.9	4.4	.254	3 to 3-1/2	8.3	1.6	8.43	Q
M8 x 1.25-6H	13.5	6.1	.254	3 to 3-1/2	10.4	1.6	10.49	Z
M10 x 1.25-6H	16.2	7.5	.254	4 to 4-1/2	12.6	1.6	12.70	1/2

RIVSCREW® THREADED RIVETS

Combining the **installation ease of a rivet with the removability of a screw**, Rivscrew® threaded speed fasteners are an excellent solution for plastic and mixed material applications requiring light clamp.

Installation Sequence

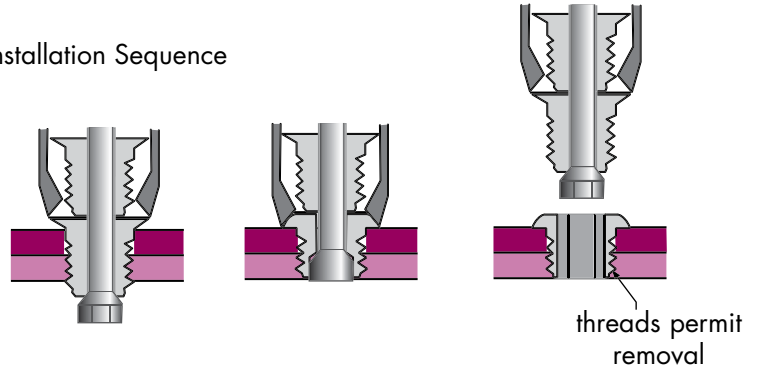

Rivscrew® Speed Fastener



KEY ADVANTAGES

- Installs quickly and easily in blind applications
- Consistent clamp provides excellent thermal transmission for semiconductors

FEATURES & BENEFITS

Expands radially during installation to form a thread in host material

- Permits removability for service with an Allen key
- Provides increased pull-out resistance in thermoplastics
- Provides controlled clamp load
- Provides high resistance to vibration

Installs quickly and easily with Avdel 753 MkII tools with magazine-feed system

- Hand-held and automated systems available, including multi-head systems
- Systems can be customized to your assembly line requirements

Rivscrew fasteners can also be installed countersunk. Please contact a Textron Fastening Systems applications engineer for assistance.

SPECIFICATIONS

Sizes • M2.8 – M4.0

Head Styles • Domed

Materials • Steel

Finishes • Zinc and gold passivated; zinc and hot tin dipped; zinc and black passivate; and zinc and molybdenum disulphide

APPLICATIONS

Thermoplastics and thermoset plastics, including attachment of semi-conductors to PCBs

RIVSCREW® THREADED RIVETS

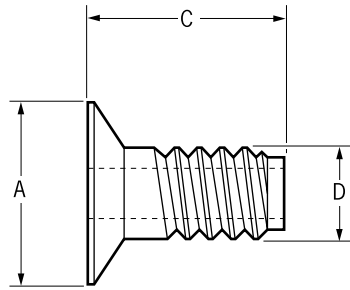

Before Placement

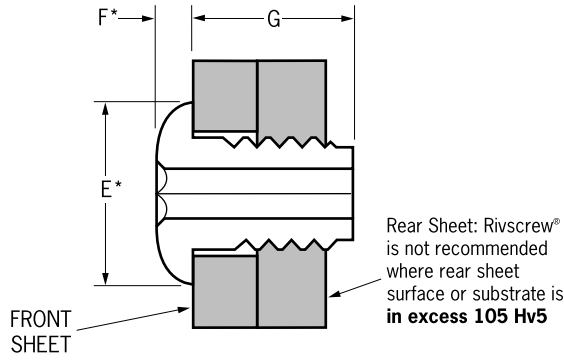

After Placement

FASTENER REMOVAL	
Fastener Dia.	Hex Key Dia.
2.8mm	1/16"
3.0mm	1/16"
3.5mm	2mm
4.0mm	2.5mm

DIMENSIONAL DATA – METRIC SIZES

Fastener Size nom.	Grip Range min. max.		Hole Size				Before Placement			After Placement			
			Front Sheet		Rear Sheet		Head Dia. A		Shank Dia. D	Head Dia. E*	Head Thck. F*	Underhead Length G	
			min.	max.	min.	max.	min.	max.	max.	max.	max.	max.	
2.8	1.62	2.85							5.2				4.0
	1.62	3.85							6.1				5.0
	1.62	4.83	2.95	3.02	2.62	2.70	5.4	5.9	7.1	2.6	6.1	1.4	6.0
	1.62	5.82							8.1				7.0
3.0	1.62	7.80							10.1				9.0
	1.62	2.85							5.2				4.0
	1.62	3.85							6.1				5.0
	1.62	4.83							7.1				6.0
	1.62	5.82	3.07	3.15	2.82	2.89	5.4	5.9	8.1	2.8	6.1	1.4	7.0
	1.62	6.81							9.1				8.0
	1.62	7.80							10.1				9.0
3.5	1.62	10.72							13.1				11.9
	1.62	2.85							5.2				4.0
	1.62	3.85							6.1				5.0
	1.62	4.83							7.1				6.0
	1.62	5.82	3.50	3.58	3.10	3.17	5.6	6.0	8.1	3.1	6.1	1.4	7.0
	1.62	6.81							9.1				8.0
	1.62	7.80							10.1				9.0
4.0	1.62	11.76							14.1				12.9
	1.62	2.85							5.2				4.0
	1.62	3.85							6.1				5.0
	1.62	4.83							7.1				6.0
	1.62	5.82	4.19	4.27	3.61	3.68	5.8	6.2	8.1	3.6	6.4	1.4	7.0
	1.62	6.81							9.1				8.0
	1.62	7.80							10.1				9.0
	1.62	9.78							12.1				11.0

OTHER THREADED FASTENERS FOR PLASTICS

PUSHTITE® & PUSHTITE II THREAD-FORMING FASTENERS

The unique thread profile of Pushtite fasteners allows them to be simply pressed into place, virtually eliminating strip-out during initial assembly and providing high pull-out strength.

- Tri-roundular shape minimizes stress on the boss
- Screws can be removed and reinserted if necessary, or can be made tamper-resistant
- Can be gang-driven, which can cut costs
- Allows displaced air to escape during insertion to prevent pneumatic failure of boss

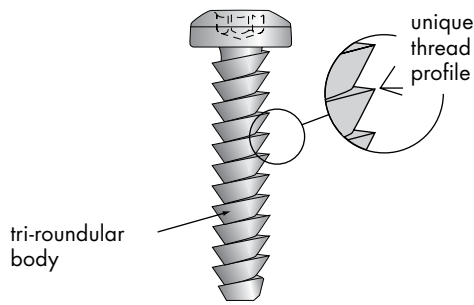

BF-PLUS THREAD-CUTTING FASTENERS

The unique thread-cutting flutes of the BF-Plus fastener were designed to provide deep, fully-cut mating threads with minimal contamination. It helps ensure reliable fastening in harder plastics.

- Multiple flutes for thread cutting extend through first full thread diameter to reduce radial stress and boss damage
- 5° reverse angle of flutes retains chips to minimize contamination
- 48° thread profile with extended height, combined with a longer pitch length, increases flank and shear area to increase pull-out resistance and strip-out resistance

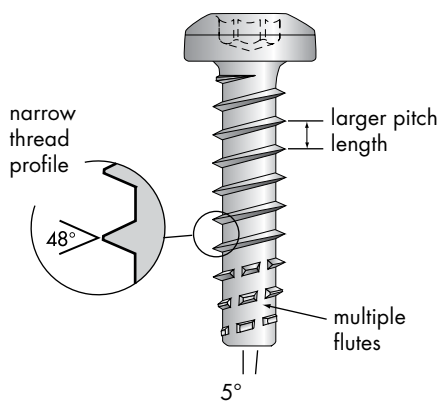

DURO-PT® THREAD-FORMING FASTENERS

Duro-PT® thread-forming fasteners are engineered to meet the unique requirements of reinforced thermoplastics and light alloys.

- Asymmetrical 30° thread profile reduces radial stress and minimizes installation torque
- Allows deep thread engagement to increase pull-out strength and increase resistance to vibration loosening
- Eliminates need for supplementary locking devices
- Recessed thread root provides space for displaced material, minimizing risk of clogging and galling during assembly

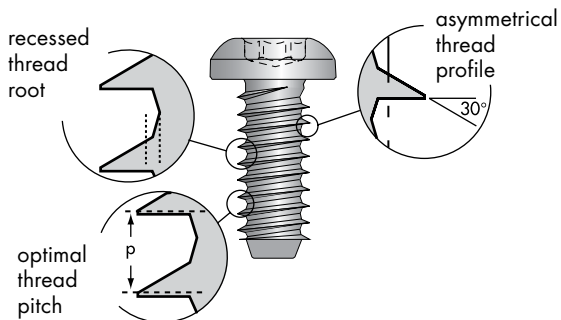

HI-WIDE THREAD-FORMING FASTENERS

- Large minor diameter
- 40°, 45°, or 48° thread profiles available
- Wide thread spacing for greater shear area to increase pull-out resistance
- Thread-forming and thread-cutting styles are available
- Variety of point styles available for thread-forming screws

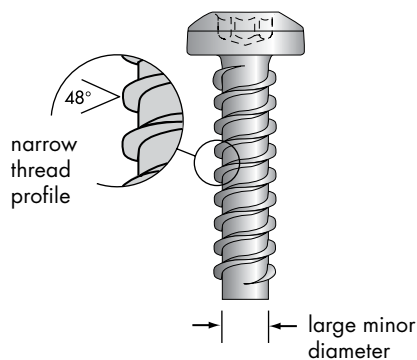

TORX PLUS® DRIVE SYSTEM

The TORX PLUS® Drive System is the ideal drive system for screws for plastics, since it provides optimum torque transfer, even when forming or cutting threads in reinforced plastics. Its unmatched ability to increase productivity by outperforming competing drive systems can lower assembly costs.



SPECIFICATIONS

Drive Sizes • 1IP – 100IP (recess) to fit screw sizes M0.9 – M24 (#0 – 1")

Styles • Internal, external, low-profile external, tamper-resistant, TORX PLUS® Drive/external hex or TORX PLUS Drive/slotted

Drive Tools • TORX PLUS Drive tools fit both inch and metric fasteners. Standard and special tooling is available from over 3,000 outlets around the world. For more information, please contact Textron Fastening Systems.

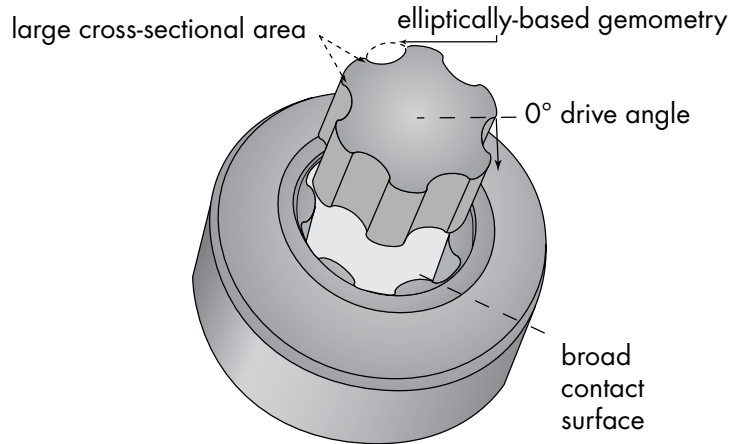

TORX PLUS® Drive System

KEY ADVANTAGES

- Allows optimum torque transfer for forming or cutting threads in plastic applications

FEATURES & BENEFITS

Unique, elliptically-based geometric configuration to maximize engagement between driver and fastener

True 0° drive angle virtually eliminates the radial forces that cause stress on fastener recesses with vertical walls

- Allows optimum torque transfer, even in plastics reinforced with nylon or carbon fibers

Vertical sidewalls completely enclose the driver tip, reducing tool slippage and virtually eliminating camout

- Prevents damage to the fastener and surrounding surfaces, which often occurs with cross recess fasteners
- Eliminates the debris camout can create, which can damage sensitive applications
- Minimizes damage to application

Higher torque removal capability than any other drive system

- Helps minimize damage to boss from removal and reinsertion of the screw

Improved fit between fastener and tool minimizes wear on the drive bit

- Drive bit life lengthened as much as 12 times
- Downtime and costs are reduced since significantly fewer drive bit changes are required

G L O S S A R Y

BOSS: Protuberance on a plastic part designed to add strength and/or facilitate fastening or alignment.

CREEP: Permanent deformation of a material caused by time, temperature and pressure.

DRAFT ANGLE: The amount of slope in the boss hole and/or outside edge, measured from a line perpendicular to the bottom of the boss.

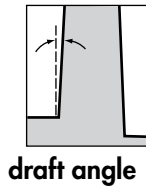

FILLERS: Additives or reinforcements that are added to a polymer to change one or more of its characteristics such as strength, wear resistance, etc.

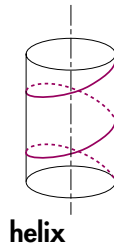

FLANK ANGLE: See thread profile.

HELIX ANGLE: The angle between the helix of the thread and a line perpendicular to the axis of the screw.

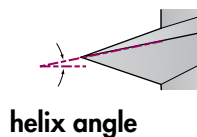

LEAD THREAD: The thread length from where it starts to where it becomes full size. This distance is usually one-half the fastener diameter.

LENGTH OF ENGAGEMENT: The length of full-sized fastener threads that engage in the nut material. The length of the lead thread is not counted in the length of engagement, since its reduced size minimizes any performance benefits. The length of engagement is usually expressed in relationship to the nominal diameter of the screw (e.g. 2 to 2-1/2 diameters of engagement).

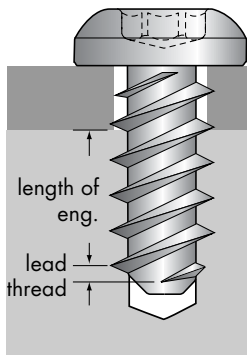

MAJOR DIAMETER: The outside or largest diameter of an external thread.

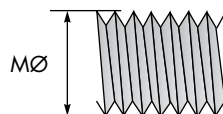

MINOR DIAMETER: The inside or smallest diameter of an external thread.

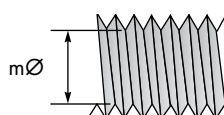

NOMINAL DIAMETER: The major diameter of a screw or, in tri-round fasteners, the "C" dimension.

PEAK DRIVE TORQUE: Amount of force required to pull the members of a joint together; the point at which clamp begins to generate.

RADIAL STRESS (hoop stress): Forces that propagate from the screw towards the outside diameter of the boss.

SHEAR: Force that tends to divide an object along a plane parallel to the opposing stresses.

THERMOPLASTIC: These widely used polymers are characterized by their ductility (fillers may be added to increase stiffness). Thermoplastics can be remelted and reformed several times without degrading the material.

THERMOSET: These polymers are characterized by extreme stiffness. The initial molding process causes a chemical reaction which "cures" the material, so the resin cannot be reprocessed.

THREAD ENGAGEMENT: The amount of thread tooth that is filled by the application material. This measurement is usually expressed as a percentage and is used to determine optimal hole size.

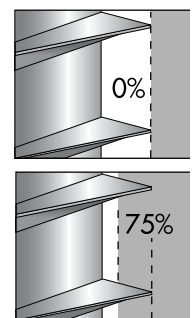

THREAD PROFILE:

The angle between the flank of the thread and a line perpendicular to the screw axis.

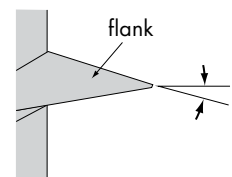

ULTIMATE TORQUE: The amount of force at which a fastener begins to strip or otherwise fail in a joint.

SUCCESS WITH TEXTRON FASTENING SYSTEMS

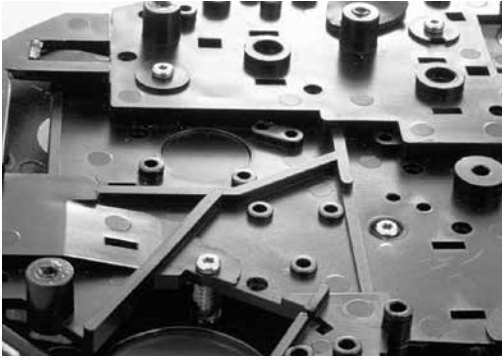

MEETING THE NEEDS OF DEMANDING APPLICATIONS

This stereo/heating control panel cover is made from a particularly brittle plastic which is very prone to strip-out. Textron Fastening Systems recommended a PT® screw with TORX PLUS® Drive System to attach the cover to the dashboard. The PT thread minimizes strip-out, while the TORX PLUS Drive ensures that the proper torque level is reached easily, preventing over-clamping. The customer is saving \$105 per car in replacement/warranty costs.



REDUCING COSTS BY SIMPLIFYING ASSEMBLY

The original assembly of a pocket pager required threading a machine screw into a brass insert that was press-fit into the mating case housing – a costly and inefficient process. Textron Fastening Systems designed a Plastite screw with TORX PLUS Drive that replaced the entire insert combination. This made assembly more efficient and allowed the company to realize substantial cost savings.



SECURING A WIDE RANGE OF MATERIALS

A leading manufacturer of automotive HVAC products uses Powergrip fasteners in their blower motor assembly. This involves fastening four stacked components – one sheet metal, two plastic, and one rubber – to a sheet metal housing. The Powergrip® fastener positions the rubber and plastic components without crushing them, while securing them to the metal. Using one fastener for all materials has helped speed assembly, resulting in increased productivity.



IMPROVING RELIABILITY THROUGH PROPER DESIGN

The manufacturer of these automotive headlamps switched to a Duro-PT® thread-cutting screw, which allowed them to eliminate a supplemental gluing operation and still reduce vibration loosening problems. The result was a higher quality product and reduced warranty costs.

SUCCESS WITH TEXTRON FASTENING SYSTEMS

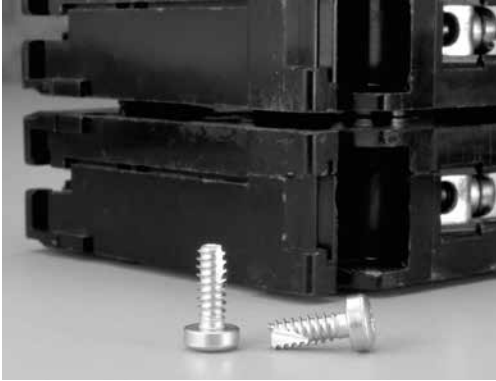

IMPROVING PERFORMANCE & REDUCING COSTS

Made from a thermoset plastic, an industrial circuit breaker originally utilized a threaded insert/machine screw combination. Engineers knew that replacing this combination with a single screw would reduce costs, so they tested several different fasteners in the application. A Duro-PT® screw with TORX PLUS® Drive outperformed all of them. The thread design provides the high resistance to strip-out and vibration loosening they need, while the TORX PLUS Drive optimizes the torque transfer required to cut threads in the hard material.



MAINTAINING INTEGRITY OF APPLICATIONS

Normal in-service loads caused boss cracking problems, loose fasteners and rattle problems in these glove box doors, resulting in high warranty costs. Textron Fastening Systems was called in to offer an alternative that would allow the customer to use their existing design. They developed a PT® screw that eliminated boss cracking, offered positive resistance to vibration loosening, and eliminated rattles in the dashboard from the glove box door.



INCREASING ASSEMBLY EFFICIENCY

A patented design for an automotive fluid reservoir and fan shroud required a fastener that could be included in the blow-molding process and would maintain the integrity of the application. Textron Fastening Systems designed a PlasTORX® stud that is molded directly into the unit, eliminating through holes and resulting in a more cost-efficient assembly. Because of their high resistance to rotation and pull-out, the PlasTORX studs also increase the reliability of the application.



ELIMINATING PROBLEMS ON THE ASSEMBLY LINE

Cracking and boss failure were common problems for an audio components manufacturer who tried to seat sheet metal screws in plastic bosses. Textron Fastening Systems applications specialists reviewed the application and determined that a Plastite® fastener would fit in the current boss design. The Plastite fastener generates less radial stress in the application than the sheet metal screw, so boss damage is minimized, increasing product reliability.

SUCCESS WITH TEXTRON FASTENING SYSTEMS

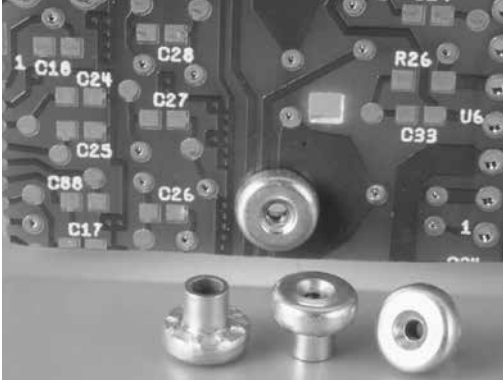

PROVIDING ASSEMBLY SOLUTIONS

A Perma-Nut™ insert is used as a nut plate by a truck manufacturer to secure a circuit board to the vehicle. The board, which is .060" (1.52mm) thick, is extremely fragile and subject to failure if placed under stress during installation. Textron Fastening Systems designed this Perma-Nut insert with M2 threads which eases assembly by providing a system where the nuts are already in place, eliminating the difficulty of assembling loose nuts in a hard-to-reach area.



INCREASING PRODUCT RELIABILITY

The design of this stadium seating, made of polypropylene, was changed to include brackets with a powder coating. The Plastite® fasteners used in the original design could not meet the new performance requirements. The manufacturer switched to PT fasteners, which provide the necessary resistance to pull-out. Therefore, the seats are less likely to be damaged from vibration and other in-use conditions.



IMPROVING PRODUCT PERFORMANCE

In order to eliminate rattle problems in a radio/cassette tape bin, the manufacturer converted to a PT® screw sized to meet the existing boss design. The PT screw minimizes clamp load loss to protect against vibration loosening and ensure a high load-carrying capability. This in turn increases the product's quality and reliability, helping to increase customer satisfaction.

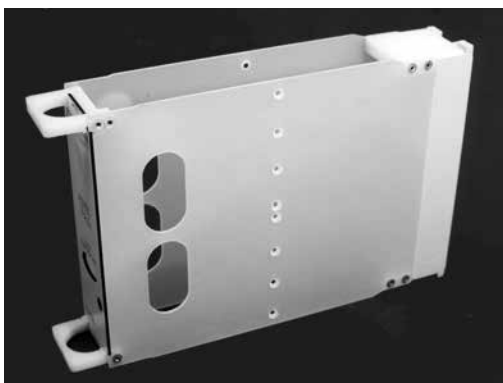

SOLVING MULTIPLE ASSEMBLY PROBLEMS

A manufacturer of relay monitoring equipment needed to assemble banks of PCB modules contained in nylon outer module chassis, which are installed into sub-racks. Rivscrew® was specified to assemble the outer casings as well as the relay modules. The Rivscrew fasteners provided rapid one-sided installation, high residual clamp-up, resistance to vibration, and left a flush surface so that modules could be slotted side by side with no air gaps. In the case of the relay modules, the Rivscrew fastener is placed directly into a pre-drilled hole in the nylon chassis material and forms a radial thread during placement. This enables good vibration resistance and ensures no residue is generated.

OTHER FASTENERS FOR PLASTICS

Textron Fastening Systems (TFS) offers a number of blind and two-piece fasteners to increase efficiency on your assembly line. Many different types of installation equipment, from hand-held to customized robotic systems, are available to meet your specific requirements.

AVDEL SPEED FASTENING SYSTEMS



Avtronic®, Briv®, Chobert®, and Grovit™ speed fastening systems allow rapid and reliable assembly of a wide range of plastics. They are engineered to meet the demanding requirements of high-performance assemblies such as semi-conductors and printed circuit boards.

- Rapid, blind-side assembly
- Consistent clamp and grip
- Good vibration resistance
- Precision fastening

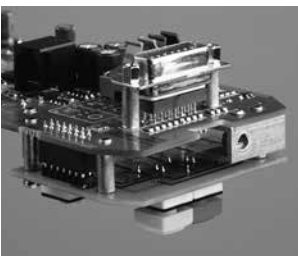

Avsert® stand-off pillars and Avlug™ terminal posts are designed to provide fast, reliable assembly to printed circuit boards.

- Avsert pillars feature an internal bore ready to accept a fixing screw, and are brass-tin plated to ease soldering
- Avlug terminal posts feature annular grooves to assist wire wrapping in readiness for soldering



BREAKSTEM FASTENING SYSTEMS



Avibulb®, aluminum Avex®, Bulbex®, Klamp-tite®, Stavex®, T-Lok™, and TLR™ breakstem systems provide excellent multi-grip performance.

- Large blind-side bearing area
- Positively retained stems

LOCKBOLT FASTENING SYSTEMS



CherryMate™ two-piece rivets do not require high tolerance holes and have an extra-wide grip range – up to 4". They clamp securely without crushing the parent material.



Camtainer® and Avtainer® lockbolt systems are used to fasten composite materials to metal, and provide excellent performance in GRP/FRP panels.

- Provide high shear and tensile strength
- Fully sealed for water/air tight joints
- Tamper-resistant

BLIND THREADED INSERTS



A variety of blind threaded inserts are available, designed to meet

the needs of specific applications. Testing of plastic applications is required to determine proper use.

MORE TEXTRON FASTENING SYSTEMS SOLUTIONS



TEXTRON FASTENING SYSTEMS

Headquartered in Troy, Michigan, Textron Fastening Systems (TFS) has over 12,000 employees around the world. TFS is a \$1.7 billion segment of Textron, a Fortune 150 company. TFS provides a full range of products and services, including cold formed components, threaded fasteners, molded plastic components, engineered assemblies, blind fastening systems, automation systems, engineering services and vendor-managed inventory services. Globally-recognized brand names include Avdel®, Cherry®, Camcar®, Elco®, and Sükosim®.

INFORMATION ONLINE

For the latest fastening and assembly information, go to www.textronfasteningsystems.com. Everything from product descriptions and technical data to application and design assistance is included for the entire range of Textron Fastening Systems products and services.

Design and technical information on the wide range of threaded and non-threaded fasteners for plastics available from TFS can be found at www.fastenersforplastics.com. The site includes a fastener selection guide, dimensional data, design information, links to TFS engineered standards catalogs, and more.



ENGINEERED ASSEMBLIES

To lower costs, manufacturers utilize TFS engineered assemblies, which combine diverse components, such as cold formed, metal stamped, plastic molded, and die-cast parts, into a single module ready for installation.

Each assembly is designed and tested to meet the specific requirements of its unique application. Products include bubble level aim indicators, digital clock housings, wheel adjusters, light adjusting systems, governor assemblies, and more components for both automotive and non-automotive markets.



LOGISTICS SERVICES

Global vendor-managed inventory programs, global warehousing and distribution programs, global supply capabilities, JIT and Kan Ban programs, custom packaging and more are among our complete range of logistics services. These capabilities allow us to design a custom program to meet your global requirements.

VALUE-ADDED SERVICES FROM TFS



Design Assistance • Textron Fastening Systems uses a variety of methods to evaluate the many different aspects of your application. Simultaneous engineering, analysis, and hands-on testing are used to examine material, assembly conditions, and proper joint design.



Quality Assurance • We utilize "quality at the source" methods to ensure product quality and consistency. Textron Fastening Systems has multiple A2LA-accredited labs, and every operation is certified to the ISO 9000 and/or QS-9000 series of quality standards.

Textron Fastening Systems offers a wide range of services to increase your assembly efficiency and improve end product quality.



Product Testing • Textron Fastening Systems' test labs can closely simulate your application and assembly conditions. We can verify the performance of our products to ensure product reliability before it is shipped.



Product Teardowns • Your product is completely disassembled and analyzed by our engineers to evaluate joint design and identify possible cost savings from fastener consolidation and/or improved assembly methods.

The information in this manual is not to be considered a specification.

TORX®, TORX PLUS®, PlasTORX®, Powergrip®, Pushfite®, Perma-nut™, Avdel®, Cherry®, Camcar®, Elco®, Sükosim®, Rivscrew®, Avtronic®, Avlug™, Avsert®, Briv®, Chobert®, Grovit™, Avibulb®, Avex®, Bulbex®, TLR™, Klamp-tite®, Stavex®, T-Lok™, CherryMate™, Camtainer® and Avtainer® are trademarks of Textron Inc. PT® is a registered trademark of EJOT Verbindungstechnik & Co. KG. Plastite® is a registered trademark of Research Engineering & Manufacturing Inc.

TEXTRON Fastening Systems

516 Eighteenth Avenue
Rockford, IL 61104-5181

1.800.544.6117 (U.S. and Canada)

voice: 815.961.5300

fax: 815.961.5345

www.fastenersforplastics.com



TEXTRON Fastening Systems

516 Eighteenth Avenue
Rockford, IL 61104-5181

1.800.544.6117 (U.S. and Canada)

voice: 815.961.5300

fax: 815.961.5345

www.fastenersforplastics.com

